

The Building Regulations 2000

## Conservation of fuel and power

**APPROVED DOCUMENT**



**L1 Conservation of fuel and power in dwellings**

Coming into effect 1 April 2002

The Stationery Office

**2002 EDITION**

## MAIN CHANGES IN THE 2002 EDITION

**1** This Approved Document L1 replaces the content of the 1995 edition of Approved Document L that relates to dwellings. The main changes made by the Building Regulations (Amendment) Regulations 2001 and in the guidance in this document are as follows.

### Changes in the requirements

**2** Part L of Schedule 1, which sets out the legal requirements for the conservation of fuel and power in buildings, has been subdivided into Part L1, covering dwellings, and Part L2, covering other types of buildings. This Approved Document only gives guidance on complying with Part L1.

**3** In Part L1, the requirement applying to heating and hot water systems has been changed to encompass overall system performance rather than just controls. This means that boiler seasonal efficiency and inspection and commissioning are now covered.

**4** In Part L1, new requirements with no limits on application are introduced covering efficient internal and external lighting systems fixed to the dwelling (and appropriate controls for external lighting), and the provision of information for householders. The information is required to enable householders to operate and maintain the heating, hot water and external lighting systems effectively.

**5** In Regulation 2 the definition of controlled service has been expanded to include services and fittings in relation to which Part L1 imposes a requirement. In Regulation 3 a new sub-paragraph 1(A) limits the application of this new definition of controlled service to existing dwellings so that replacement work on windows and other glazed elements, boilers and hot water vessels is now controlled.

**6** Regulation 18 is amended to enable local authorities to test the compliance of buildings and controlled services and fittings for compliance with the technical requirements in Part L1.

### Changes in the technical guidance

**7** A summary guide to the use of the Approved Document is given at page 5.

**8** The standards of fabric insulation have improved by changing the methods of calculating U-values to those in the European Standards and by setting lower (i.e. better) values.

**9** The nominal average U-value for windows and other glazed elements has been improved and is now based on sealed double-glazing units with low-emissivity inner panes and 16mm air gaps. Metal windows are given some credit for their thinner framing members and hence the increased useful solar gain. The base area allowance has been increased to 25% to give more daylighting design flexibility.

**10** The Elemental Method now includes boiler efficiency and it has been constrained as a simple approach where trading off between elements and boilers is only possible for complete dwellings.

**11** The Target U-value Method is retained and the provisions for trading off between fabric and heating system performance have been improved.

**12** The Energy Rating Method which used SAP Ratings has been replaced by the new Carbon Index Method. However, to comply with the requirements in Regulation 16 of the Building Regulations 2000 and in Regulation 12 of the Building (Approved Inspectors etc.) Regulations 2000, SAP Ratings must continue to be notified to building control bodies and posted as notices in new dwellings.

**13** The guidance on reducing thermal bridging has been improved and new guidance is given on reducing unwanted air leakage. A way of achieving compliance with these requirements is to adopt robust construction detail designs that have been specially published for this purpose.

**14** New guidance is given on complying with the requirements for commissioning heating and hot water systems, for lighting and for the provision of information for householders.

**15** The guidance on conservatories has been extended to cover conservatories attached to existing dwellings.

**16** The guidance on material alterations and changes of use remains unchanged, but it has been placed in a new section along with the new guidance on work on controlled services in existing dwellings and the guidance relevant to conservation and restoration work in historic buildings.

**17** The guidance suggests, in paragraph 1.49, the provision of certificates or declarations of compliance from suitably qualified persons.

# Contents

	PAGE		PAGE
<b>CONTENTS</b>	1	Commissioning of for heating and HWS systems	16
<b>Use of Guidance</b>	3	Operating and maintenance instructions for heating and HWS system controls	17
Summary guide to the use of this Approved Document	5	Insulation of pipes and ducts	17
The Requirements	7	Internal lighting	17
<b>Section 0 : General</b>	9	External lighting fixed to the building	18
Performance	9	Conservatories	18
Introduction to provisions	9	<b>Section 2 : Work on existing dwellings</b>	19
Technical risk	9	Replacement of controlled services or fittings	19
Thermal conductivity and transmittance	9	Material alterations	20
U-value reference tables	10	Material changes of use	20
Calculation of U-values	10	Historic buildings	21
Roof window	11	<b>APPENDICES</b>	
Basis for calculating areas	11	<b>Appendix A : Tables of U-values</b>	22
Air permeability	11	<b>Appendix B : Calculating U-values</b>	35
Standard assessment procedure (SAP)	11	<b>Appendix C : U-values of ground floors</b>	41
Historic buildings	11	<b>Appendix D : Determining U-values for glazing</b>	44
<b>Section 1 : Design and construction</b>	12	<b>Appendix E : Target U-value examples</b>	45
Alternative methods of showing compliance	12	<b>Appendix F : SAP Ratings and Carbon Indexes</b>	48
Elemental Method	12	<b>Appendix G : Carbon Index</b>	51
U-values for construction elements	12	British Standards referred to	54
Heating efficiency	12	Other documents referred to	55
Areas for windows, doors and rooflights	13		
Extensions to dwellings	13		
Summary of provisions in the Elemental Method	13		
Target U-value method for new dwellings	13		
Optional allowance for solar gains	14		
Carbon Index Method	14		
Constraints when using the calculation procedures	15		
Poorest acceptable U-values	15		
Limiting thermal bridging at junctions and around openings	15		
Limiting air leakage	15		
Space heating system controls	15		
Zone controls	16		
Timing controls	16		
Boiler control interlocks	16		
Hot water systems	16		
Alternative approach for space heating and HWS systems	16		



# Use of guidance

## THE APPROVED DOCUMENTS

This document is one of a series that has been approved and issued by the Secretary of State for the purpose of providing practical guidance with respect to the requirements of Schedule 1 to and regulation 7 of the Building Regulations 2000 (SI 2000/2531) for England and Wales. SI 2000/2531 has been amended by the Building (Amendment) Regulations 2001 (SI 2001/3335).

**At the back of this document is a list of all the documents that have been approved and issued by the Secretary of State for this purpose.**

Approved Documents are intended to provide guidance for some of the more common building situations. However, there may well be alternative ways of achieving compliance with the requirements. **Thus there is no obligation to adopt any particular solution contained in an Approved Document if you prefer to meet the relevant requirement in some other way.**

### Other requirements

The guidance contained in an Approved Document relates only to the particular requirements of the Regulations which the document addresses. The building work will also have to comply with the requirements of any other relevant paragraphs in Schedule 1 to the Regulations.

There are Approved Documents which give guidance on each of the Parts of Schedule 1 and on regulation 7.

## LIMITATION ON REQUIREMENTS

In accordance with regulation 8, the requirements in Parts A to K and N (except for paragraphs H2 and J6) of Schedule 1 to the Building Regulations do not require anything to be done except for the purpose of securing reasonable standards of health and safety for persons in or about buildings (and any others who may be affected by buildings or matters connected with buildings).

Paragraphs H2 and J6 are excluded from Regulation 8 because they deal directly with prevention of the contamination of water. Parts L and M are excluded because they respectively address the conservation of fuel and power and access and facilities for disabled people. These matters are amongst the purposes, other than health and safety, that may be addressed by Building Regulations.

## MATERIALS AND WORKMANSHIP

Any building work which is subject to the requirements imposed by Schedule 1 to the Building Regulations should, in accordance

with regulation 7, be carried out with proper materials and in a workmanlike manner.

You may show that you have complied with regulation 7 in a number of ways. These include the appropriate use of a product bearing CE Marking in accordance with the Construction Products Directive (89/106/EEC)<sup>1</sup> as amended by the CE Marking Directive (93/68/EEC)<sup>2</sup>, or a product complying with an appropriate technical specification (as defined in those Directives), a British Standard, or an alternative national technical specification of any state which is a contracting party to the European Economic Area which, in use, is equivalent, or a product covered by a national or European certificate issued by a European Technical Approval issuing body, and the conditions of use are in accordance with the terms of the certificate. You will find further guidance in the Approved Document supporting regulation 7 on materials and workmanship.

### Independent certification schemes

There are many UK product certification schemes. Such schemes certify compliance with the requirements of a recognised document which is appropriate to the purpose for which the material is to be used. Materials which are not so certified may still conform to a relevant standard.

Many certification bodies which approve such schemes are accredited by UKAS.

### Technical specifications

Under section 1(a) of the Building Act, Building Regulations may be made for various purposes including health, safety, welfare, convenience, conservation of fuel and power and prevention of contamination of water. Standards and technical approvals are relevant guidance to the extent that they relate to these considerations. However, they may also address other aspects of performance such as serviceability, or aspects, which although they relate to the purposes listed above, are not covered by the current Regulations.

When an Approved Document makes reference to a named standard, the relevant version of the standard is the one listed at the end of the publication. However, if this version has been revised or updated by the issuing standards body, the new version may be used as a source of guidance provided it continues to address the relevant requirements of the Regulations.

<sup>1</sup> As implemented by the Construction Products Regulations 1991 (SI 1991/1620).

<sup>2</sup> As implemented by the Construction Products (Amendment) Regulations 1994 (SI 1994/3051).

The appropriate use of a product which complies with a European Technical Approval as defined in the Construction Products Directive will meet the relevant requirements.

The Department intends to issue periodic amendments to its Approved Documents to reflect emerging harmonised European Standards. Where a national standard is to be replaced by a European harmonised standard, there will be a co-existence period during which either standard may be referred to. At the end of the co-existence period the national standard will be withdrawn.

## **THE WORKPLACE (HEALTH, SAFETY AND WELFARE) REGULATIONS 1992**

The Workplace (Health, Safety and Welfare) Regulations 1992 contain some requirements which affect building design. The main requirements are now covered by the Building Regulations, but for further information see – *Workplace health, safety and welfare. Workplace (Health, Safety and Welfare) Regulations 1992. Approved Code of Practice L24*. Published by HSE Books 1992; ISBN (0 7176 0413 6).

The Workplace (Health, Safety and Welfare) Regulations 1992 apply to the common parts of flats and similar buildings if people such as cleaners and caretakers are employed to work in these common parts. Where the requirements of the Building Regulations that are covered by this Part do not apply to dwellings, the provisions may still be required in the situations described above in order to satisfy the Workplace Regulations.

# Summary guide to the use of this approved document

<i>Routes to compliance for dwellings</i>			
STEP	TEST	ACTION	
<b>START</b>	<b>Choose method of compliance</b>		
	Elemental method	Go to 1	
	Target U-value method	Go to 5	
	Carbon Index method	Go to 11	
<b>Compliance by Elemental method</b>			
1	Is the heating by gas or oil boiler, heat pump, community heating with CHP, biogas or biomass fuel?	No Yes	Elemental Method not applicable - go to START and choose another method Continue
2	For gas or oil boilers, is the SEDBUK of proposed heating system $\geq$ SEDBUK from Table 2 in 1.7? [Note: for heat pump, CHP, biogas or biomass fuel, efficiency is not an issue, so continue]	No Yes	Change heating system and go to 1 Continue
3	Are all U-values of proposed dwelling $\leq$ the corresponding values from Table 1 in 1.3?	No	<b>FAIL</b> by Elemental Method - revise U-values and repeat 3 or go to START
4	Is the area of windows, doors and roof windows $\leq$ 25% of total floor area?	Yes No Yes	Continue <b>FAIL</b> by Elemental Method - reduce area of openings and repeat 4 or go to START <b>PASS</b> by Elemental Method and go to Additional checks
<b>Compliance by Target U-value method</b>			
5			Calculate the target U-value ( $U_T$ ) from equation (1) in 1.18
6	Is the heating by a system <u>other than</u> gas or oil boiler, heat pump, CHP, biogas or biomass fuel, or is it undecided?	Yes No	Divide the target U-value ( $U_T$ ) by 1.15 and go to 8 Continue
7	For gas or oil boilers, is the proposed SEDBUK for the heating system equal to the corresponding SEDBUK from Table 2 in 1.7? [Note: for heat pump, CHP, Biogas or Biomass fuel, efficiency is not an issue, so continue]	Yes No	Multiply the target U-value ( $U_T$ ) by $\frac{\text{proposed SEDBUK}}{\text{SEDBUK from Table 2}}$ Continue
8	Is there a greater area of glazing facing South than is facing North?	Yes No	Add: $0.04 \times \frac{A_S - A_N}{A_T}$ to the Target U-value ( $U_T$ ) Continue
9			Calculate the average U-value from $\bar{U} = \frac{\sum AU}{\sum A}$
10	Is $\bar{U} \leq U_T$ and is the U-value of each element $\leq$ corresponding value from Table 3 in 1.29?	No Yes	<b>FAIL</b> by Target U-value Method - revise and go to 5 or go to <b>START</b> <b>PASS</b> by Target U-value method and go to Additional checks
<b>Compliance by Carbon Index method</b>			
11			Calculate the Carbon Index (CI) as defined in SAP 2001
12	Is the Carbon Index (CI) $\geq$ 8.0 and is the U-value of each element $\leq$ corresponding value from Table 3 in 1.29?	No Yes	<b>FAIL</b> by Carbon Index Method - revise and go to 11 or go to START <b>PASS</b> by Carbon Index method and go to Additional checks

## Additional checks by builders

### Limiting thermal bridging at junctions and around openings (see clauses 1.30 to 1.32)

Check that details comply with clauses 1.30 or that calculations show equivalence

### Limiting air leakage (see clauses 1.33 to 1.35)

Check that air leakage is limited according to clauses 1.34 or 1.35

### Space heating controls and HWS (see clauses 1.36 to 1.45)

Zone controls:	Check that zone controls comply with clauses 1.38 and 1.39
Timing controls:	Check that timing controls comply with clause 1.40
Boiler control interlocks:	Check that boiler control interlocks comply with clause 1.41
Hot Water Storage:	Check that hot water storage complies with clauses 1.42 to 1.45

### Alternative approach for space heating and HWS systems (see clause 1.46)

Check that the space heating and hot water systems comply by adopting the relevant recommendations in Good Practice Guide 302 and that provision has been made to include zoning, timing and interlock features similar to those given in clauses 1.36 to 1.45

### Commissioning of heating and HWS systems (see clauses 1.47 to 1.49)

Inspect, commission and test systems OR check that the installation sub-contractor has certified, following commissioning, that the systems comply.

### Operating and Maintenance instructions for heating and hot water systems (see clause 1.50)

Check that the building owner and/or occupier has been given information on the operation and maintenance of the heating and hot water systems.

### Insulation of pipes and ducts (see clauses 1.51 and 1.52)

Check that reasonable provision has been made to insulate pipes and ducts, and that in unheated areas the central heating and hot water pipework has been insulated sufficiently to protect against freezing.

### Internal Lighting (see clauses 1.53 to 1.55)

Check that reasonable provision has been made for occupiers to obtain the benefits of efficient lighting.

### External lighting fixed to the building (see clause 1.56)

Check that reasonable provision has been made to enable effective control and/or use of efficient lamps.

### Conservatories (see clauses 1.57 to 1.61)

When part of a new dwelling:	<p>a) Check, where the conservatory is not separated from the rest of the dwelling, that the conservatory has been treated as an integral part of the dwelling.</p> <p>b) Check, where the conservatory is separated from the rest of the dwelling and has a fixed heating installation, that the heating in the conservatory has its own separate temperature and on/off controls.</p>
When attached to an existing dwelling:	Check, that where an opening is created or enlarged, provision has been made to limit the heat loss from the dwelling such that it is no worse than before the work was undertaken.
In addition:	Check, that with regard to the glazing, the safety requirements of Part N of the Building Regulations have been met.



# The Requirements

## CONSERVATION OF FUEL AND POWER THE REQUIREMENT L1

This Approved Document, which takes effect on 1 April 2002, deals with the following Requirements which are contained in the Building Regulations 2000 (as amended by SI 2001/3335).

<i>Requirement</i>	<i>Limits on application</i>
<b>Dwellings</b>	
<p><b>L1.</b> Reasonable provision shall be made for the conservation of fuel and power in dwellings by -</p> <p>(a) limiting the heat loss:</p> <p style="margin-left: 20px;">(i) through the fabric of the building;</p> <p style="margin-left: 20px;">(ii) from hot water pipes and hot air ducts used for space heating;</p> <p style="margin-left: 20px;">(iii) from hot water vessels;</p> <p>(b) providing space heating and hot water systems which are energy-efficient;</p> <p>(c) providing lighting systems with appropriate lamps and sufficient controls so that energy can be used efficiently;</p> <p>(d) providing sufficient information with the heating and hot water services so that building occupiers can operate and maintain the services in such a manner as to use no more energy than is reasonable in the circumstances.</p>	<p>The requirement for sufficient controls in requirement L1(c) applies only to external lighting systems fixed to the building.</p>

### OTHER CHANGES TO THE BUILDING REGULATIONS 2000

Attention is particularly drawn to the following changes to the provisions of the Building Regulations 2000 made by the Building (Amendment) Regulations 2001.

#### Amendment to Regulation 2 - Interpretation

The definition of controlled service or fitting in Regulation 2(1) is amended to:-

“controlled service or fitting means a service or fitting in relation to which Part G, H, J or L of Schedule 1 imposes a requirement;”.

#### Amendments to Regulation 3 - Meaning of building work

Regulation 3(1) is amended as follows:

“3.-(1) ...

(b) subject to paragraph (1A), the provision or extension of a controlled service or fitting in or in connection with a building;”

A new paragraph 3(1A) is introduced which says:

“The provision or extension of a controlled service or fitting –

- (a) in or in connection with an existing dwelling; and
- (b) being a service or fitting in relation to which paragraph L1, but not Part G, H or J, of Schedule 1 imposes a requirement,

shall only be building work where that work consists of the provision of a window, rooflight, roof window, door (being a door which together with its frame has more than 50 per cent of its internal face area glazed), a space heating or hot water service boiler, or a hot water vessel.”

**New Regulation 18 -  
Testing of building work**

A new Regulation 18 is substituted which says:-

**“Testing of building work**

The local authority may make such tests of any building work as may be necessary to establish whether it complies with regulation 7 or any of the applicable requirements contained in Schedule 1.”

# Section 0: General

## Performance

**0.1** In the Secretary of State's view requirement L1 (a) will be met by the provision of energy efficiency measures which:

- a) limit the heat loss through the roof, wall, floor, windows and doors etc by suitable means of insulation, and where appropriate permit the benefits of solar heat gains and more efficient heating systems to be taken into account; and
- b) limit unnecessary ventilation heat loss by providing building fabric which is reasonably airtight; and
- c) limit the heat loss from hot water pipes and hot air ducts used for space heating and from hot water vessels and their primary and secondary hot water connections by applying suitable thicknesses of insulation where such heat does not make an efficient contribution to the space heating.

**0.2** In the Secretary of State's view requirement L1 (b) will be met by the provision of space heating and hot water systems with reasonably efficient equipment such as heating appliances and hot water vessels where relevant, and suitable timing and temperature controls that have been appropriately commissioned such that the heating and hot water systems can be operated effectively as regards the conservation of fuel and power.

**0.3** In the Secretary of State's view requirement L1 (c) will be met by the provision of lighting systems that utilise energy-efficient lamps where this is appropriate; and that have manual switching controls or, in the case of external lighting fixed to the building, automatic switching, or both manual and automatic switching controls as appropriate, such that the lighting systems can be operated effectively as regards the conservation of fuel and power.

**0.4** In the Secretary of State's view requirement L1 (d) will be met by providing information, in a suitably concise and understandable form, and including the results of performance tests carried out during the works, that shows building occupiers how the heating and hot water services can be operated and maintained so that they use no more energy than is reasonable in the circumstances.

## Introduction to Provisions

### Technical risk

**0.5** Guidance on avoiding technical risks (such as rain penetration, condensation etc) which might arise from the application of energy conservation measures is given in BRE Report

No 262: "Thermal Insulation: avoiding risks", 2002 Edition. As well as giving guidance on ventilation for health, Approved Document F contains guidance on the provision of ventilation to reduce the risk of condensation in roof spaces. Approved Document J gives guidance on the safe accommodation of combustion systems including the ventilation requirements for combustion and the proper working of flues. Approved Document E gives guidance on achieving satisfactory resistance to the passage of sound. Guidance on some satisfactory design details is given in the report on robust construction details<sup>1</sup>.

### Thermal conductivity and transmittance

**0.6** Thermal conductivity (i.e. the lambda-value) of a material is a measure of the rate at which that material will pass heat and is expressed in units of Watts per metre per degree of temperature difference (W/mK).

**0.7** Thermal transmittance (i.e. the U-value) is a measure of how much heat will pass through one square metre of a structure when the air temperatures on either side differ by one degree. U-values are expressed in units of Watts per square metre per degree of temperature difference (W/m<sup>2</sup>K).

**0.8** Exposed element means an element exposed to the outside air (including a suspended floor over a ventilated or unventilated void, and elements so exposed indirectly via an unheated space), or an element in the floor or basement in contact with the ground. In the case of an element exposed to the outside air via an unheated space (previously known as a "semi-exposed element") the U-value should be determined using the method given in the SAP 1998 (to be replaced by SAP 2001 later in 2001). Party walls, separating two dwellings or other premises that can reasonably be assumed to be heated to the same temperature, are assumed not to need thermal insulation.

**0.9** In the absence of test information, thermal conductivities and thermal transmittances (U-values) may be taken from the tables in this Approved Document or alternatively in the case of U-values they may be calculated. However, if test results for particular materials and makes of products obtained in accordance with a harmonised European standard are available they should be used in preference.

<sup>1</sup> Limiting thermal bridging and air leakage: Robust construction details for dwellings and similar buildings, TSO, 2001

Measurements of thermal conductivity should be made according to BS EN 12664<sup>2</sup>, BS EN 12667<sup>3</sup>, or BS EN 12939<sup>4</sup>. Measurements of thermal transmittance should be made according to BS EN ISO 8990<sup>5</sup> or, in the case of windows and doors, BS EN ISO 12567-1<sup>6</sup>. The size and configuration of windows for testing or calculation should be representative of those to be installed in the building, or conform to published guidelines on the conventions for calculating U-values<sup>7</sup>.

## U-value reference tables

**0.10** Appendix A contains tables of U-values and examples of their use, which provide a simple way to establish the amount of insulation needed to achieve a given U-value for some typical forms of construction. They yield cautious results that, in practice, are equal or better than the stated U values. However specific calculations where proprietary insulation products are proposed may indicate that somewhat less insulation could be reasonable. The values in the tables have been derived taking account of typical thermal bridging where appropriate. Appendix A also contains tables of indicative U-values for windows, doors and rooflights.

## Calculation of U-values

**0.11** U-values should be calculated using the methods given in:

- for walls and roofs: BS EN ISO 6946<sup>8</sup>
- for ground floors: BS EN ISO 13370<sup>9</sup>

- for windows and doors: BS EN ISO 10077-1<sup>10</sup> or prEN ISO 10077-2<sup>11</sup>.
- for basements: BS EN ISO 13370 or the BCA/NHBC Approved Document<sup>12</sup>.

For building elements not covered by these documents the following may be appropriate alternatives: BRE guidance for light steel frame walls<sup>13</sup>, or finite element analysis in accordance with BS EN ISO 10211-1<sup>14</sup> or BS EN ISO 10211-2<sup>15</sup>. BRE guidance on conventions for establishing U-values<sup>7</sup> can be followed. Some examples of U-value calculations are given in Appendix B and Appendix C gives data for ground floors and basements.

**0.12** Thermal conductivity values for common building materials can be obtained from BS EN 12524<sup>16</sup> or the CIBSE Guide Section A3<sup>17</sup>, but for ease of reference a table of common materials is given in Appendix A. For specific insulation products, data should be obtained from the manufacturers.

**0.13** When calculating U-values the thermal bridging effects of, for instance, timber joists, structural and other framing, normal mortar bedding and window frames should generally be taken into account using the procedure given in BS EN ISO 6946 (some examples are given in Appendix B). Thermal bridging can be disregarded however where the difference in thermal resistance between the bridging material and the bridged material is less than 0.1m<sup>2</sup>K/W. For example normal mortar joints need not be taken into account in calculations for brickwork. Where, for example, walls contain in-built meter cupboards, and

<sup>2</sup> BS EN 12664:2001 Thermal performance of building materials and products – Determination of thermal resistance by means of guarded hot plate and heat flow meter methods – Dry and moist products of low and medium thermal resistance

<sup>3</sup> BS EN 12667:2000 Thermal performance of building materials and products – Determination of thermal resistance by means of guarded hot plate and heat flow meter methods – Products of high and medium thermal resistance

<sup>4</sup> BS EN 12939:2001 Thermal performance of building materials and products – Determination of thermal resistance by means of guarded hot plate and heat flow meter methods – Thick products of high and medium thermal resistance

<sup>5</sup> BS EN ISO 8990:1996 Thermal insulation – Determination of steady-state thermal transmission properties – Calibrated hot box

<sup>6</sup> BS EN ISO 12567-1:2000 Thermal performance of windows and doors – Determination of thermal transmittance by hot box method – Part 1: Complete windows and doors

<sup>7</sup> Conventions for the calculation of U-values, BRE: expected publication date early 2002

<sup>8</sup> BS EN ISO 6946:1997 Building components and building elements – Thermal resistance and thermal transmittance – Calculation method

<sup>9</sup> BS EN ISO 13370:1998 Thermal performance of buildings – Heat transfer via the ground – Calculation methods

<sup>10</sup> BS EN ISO 10077-1:2000 Thermal performance of windows, doors and shutters – Calculation of thermal transmittance – Part 1: Simplified methods

<sup>11</sup> prEN ISO 10077-2 Thermal performance of windows, doors and shutters – Calculation of thermal transmittance – Part 2: Numerical method for frames

<sup>12</sup> Approved Document – Basements for dwellings, BCA/NHBC, 1997, ISBN 0-7210-1508-5

<sup>13</sup> U-value calculation procedure for light steel frame walls, BRE, to be published

<sup>14</sup> BS EN ISO 10211-1:1996 Thermal bridges in building construction – Calculation of heat flows and surface temperatures – Part 1: General methods

<sup>15</sup> BS EN ISO 10211-2:2001 Thermal bridges in building construction – Calculation of heat flows and surface temperatures – Part 2: Linear thermal bridges

<sup>16</sup> BS EN 12524:2000 Building materials and products – Hygrothermal properties – Tabulated design values

<sup>17</sup> CIBSE Guide A: Environmental design, Section A3: Thermal properties of building structures, CIBSE, 1999

ceilings contain loft hatches, recessed light fittings, etc, area-weighted average U-values should be calculated.

## Roof window

**0.14** A roof window is a window in the plane of a pitched roof and may be considered as a rooflight for the purposes of this Approved Document.

## Basis for calculating areas

**0.15** The dimensions for the areas of walls, roofs and floors should be measured between finished internal faces of the external elements of the building including any projecting bays. In the case of roofs they should be measured in the plane of the insulation. Floor areas should include non-useable space such as builders' ducts and stairwells.

## Air permeability

**0.16** Air permeability is the physical property used to measure airtightness of building fabric. It measures the resistance of the building envelope to inward or outward air permeation. It is defined as the average volume of air (in cubic metres per hour) that passes through unit area of the structure of the building envelope (in square metres) when subject to an internal to external pressure difference of 50 Pa. It is expressed in units of cubic metres per hour, per square metre of envelope area, at a pressure difference of 50 Pa. The envelope area of the building is defined as the total area of the floor, walls and roof separating the interior volume from the outside environment, i.e. the conditioned space.

## Standard assessment procedure (SAP)

**0.17** SAP means the Government's Standard Assessment Procedure for Energy Rating of Dwellings.<sup>18</sup> The SAP is explained and defined, along with appropriate reference data and a calculation worksheet, in "The Government's Standard Assessment Procedure for Energy Rating of Dwellings"<sup>19</sup>. SAP 1998 means the 1998 Edition of the publication, and SAP 2001 means the 2001 Edition of the publication.

**0.18** The SAP provides the methodology for the calculation of the Carbon Index which can be used to demonstrate that dwellings comply with Part L (see paragraph 1.27). For the purposes of compliance with Part L of the Building Regulations, the Carbon Index should be calculated for the time being in accordance with SAP 1998 as amended by Appendix G of this Approved Document. A consolidated and updated edition of the SAP is in preparation. The Department will set out transitional arrangements for the use of the new edition when it is formally approved.

## Historic buildings

**0.19** Advice on the factors determining the character of historic buildings is set out in PPG15<sup>20</sup>. Specific guidance on meeting the requirements of Part L when undertaking work in historic buildings is given in paragraphs 2.9 to 2.11 of this Approved Document.

<sup>18</sup> Under separate provisions in Building Regulations a new dwelling created by building work, or by a material change of use in connection with which building work is carried out, must be given an energy rating, using the SAP edition having the Secretary of State's approval at the relevant time in the particular case; and the rating must be displayed in the form of a notice. Administrative guidance on producing and displaying SAP Ratings is given in DETR Circular No 07/2000 dated 13 October 2000

<sup>19</sup> Available free of charge from BRECSU Publications, tel: 01923 664258

<sup>20</sup> Planning and the historic environment, Planning Policy Guidance PPG 15, DoE/DNH, September 1994. (In Wales refer to Planning Guidance Wales Planning Policy First Revision 1999 and Welsh Office Circular 61/96 Planning and Historic Environment: Historic Buildings and Conservation Areas.)

# Section 1: Design and Construction

## Alternative methods of showing compliance

1.1 Three methods are shown for demonstrating reasonable provision for limiting heat loss through the building fabric:

- a) An Elemental method;
- b) A Target U-value method;
- c) A Carbon Index method.

1.2 The Elemental Method can be used only when the heating system will be based on an efficient gas or oil boiler, on a heat pump, on community heating with CHP or on biogas or biomass fuel, but not for direct electric heating or other systems. The Target U-value Method and the Carbon Index Method can be used with any heating system.

## Elemental method

### U-values for construction elements

1.3 The Elemental Method is suitable for alterations and extension work, and for new-build work when it is desired to minimise calculations. When using the Elemental Method, the requirement will be met for new dwellings by selecting construction elements that provide the U-value thermal performances given in Table 1.

**Table 1 Elemental Method: U-values (W/m<sup>2</sup>K) for construction elements**

Exposed Element	U-value
Pitched roof with insulation between rafters <sup>1,2</sup>	0.2
Pitched roof with integral insulation	0.25
Pitched roof with insulation between joists	0.16
Flat roof <sup>3</sup>	0.25
Walls, including basement walls	0.35
Floors, including ground floors and basement floors	0.25
Windows, doors and rooflights <sup>4</sup> (area-weighted average), glazing in metal frames <sup>5</sup>	2.2
Windows, doors and rooflights <sup>4</sup> (area-weighted average), glazing in wood or PVC frames <sup>5</sup>	2.0

Notes to Table 1:  
<sup>1</sup> Any part of a roof having a pitch of 70° or more can be considered as a wall.  
<sup>2</sup> For the sloping parts of a room-in-the-roof constructed as a material alteration, a U-value of 0.3 W/m<sup>2</sup>K would be reasonable.  
<sup>3</sup> Roof of pitch not exceeding 10°  
<sup>4</sup> Rooflights include roof windows  
<sup>5</sup> The higher U-value for metal-framed windows allows for additional solar gain due to the greater glazed proportion.

1.4 One way of achieving the U-values in Table 1 is by providing insulation of an appropriate thickness estimated from the tables in Appendix A. An alternative for walls and roofs is to use the combined method of calculation outlined in Appendix B and set out in more detail in the CIBSE Guide Section A3 1999 Edition. An alternative for floors is to use the data given in Appendix C. An alternative for basements is given in the BCA/NHBC Approved Document “Basements for dwellings”<sup>21</sup>.

1.5 Door designs can include various panel arrangements but the indicative U-values given in Appendix A, Table A1 will generally be acceptable. Single-glazed panels can be acceptable in external doors provided that the heat loss through all the windows, doors and rooflights does not exceed that of the standard provision given in paragraphs 1.8 to 1.10 below.

1.6 Care should be taken in the selection and installation of appropriate sealed double-glazed windows in order to avoid the risk of condensation forming between the panes. Guidance on avoiding this problem is given in BRE Report No 262 “Thermal insulation: avoiding risks”, 2002 edition.

## Heating efficiency

1.7 Reasonable provision for boiler efficiency would be demonstrated by using a boiler with SEDBUK<sup>22</sup> not less than the appropriate entry in Table 2.

**Table 2 Minimum boiler SEDBUK to enable adoption of the U-values in Table 1, and reference boiler SEDBUK for use in the Target U-value Method**

Central heating system fuel	SEDBUK <sup>1</sup> %
Mains natural gas	78
LPG	80
Oil	85 <sup>2</sup>

Notes to Table 2:  
<sup>1</sup> For boilers for which the SEDBUK is not available, the appropriate seasonal efficiency value from Table 4b of the SAP may be used instead (see paragraphs 0.17-0.18).  
<sup>2</sup> For oil-fired combination boilers a SEDBUK of 82%, as calculated by the SAP-98 method, would be acceptable

## Areas for windows, doors and rooflights

### Standard Area Provision

**1.8** The requirement would be met if the average U-value of windows, doors and rooflights matches the relevant figure in Table 1 and the area of the windows, doors and rooflights together does not exceed 25% of the total floor area.

**1.9** The average U-value is an area-weighted average for the whole dwelling, and depends on the individual U-values of the glazed components and door components proposed and their proportions of the total area of openings. Examples of how the average U-value is calculated are given in Appendix D.

### Adapting the Standard Area Provision for particular cases

**1.10** Areas of windows, doors and rooflights larger than that given in paragraph 1.8 may be adopted in particular cases by using the Target U-value Method to demonstrate compliance. Another option would be to reduce the area of windows, doors and rooflights to compensate for a higher average U-value (ie lower performance glazing). However reducing glazing area could lead to inadequate daylighting.

## Extensions to dwellings

**1.11** The fabric U-values given in Table 1 in the Elemental Method can be applied when proposing extensions to dwellings. The Target U-value and Carbon Index Methods can be used only if applied to the whole enlarged dwelling.

**1.12** Only when applied to extension works, the U-values in Table 1 may be varied provided that the total rate of heat loss from the extension is no higher than it would be if all elements had the U-values given in Table 1. The total rate of heat loss is the sum of (area x U-value) for all exposed elements. As an example, where the floor area and the roof area are equal, it would be acceptable for the roof to have a U-value of 0.18 W/m<sup>2</sup>K if the floor U-value is 0.23 W/m<sup>2</sup>K.

**1.13** For small extensions to dwellings (for example, ground-floor extension to single rooms such as kitchen extensions in terraced houses, porches where the new heated space created has a floor area of not more than about 6 m<sup>2</sup>), reasonable provision would be to use construction details that are no worse in energy performance terms than those in the existing building.

**1.14** The area-weighted average U-value of windows, doors and rooflights ("openings") in extensions to existing dwellings should not exceed the relevant values in Table 1. An

appropriate area provision for openings for extensions could be established where:

- the area of openings in the extension does not exceed 25% of the floor area of the extension plus the area of any windows or doors in the existing dwelling which, as a result of the extension works, no longer exist or are no longer exposed; or
- the area of openings in the enlarged dwelling does not exceed the area of openings in the existing dwelling; or
- the area of openings in the enlarged dwelling does not exceed 25% of the total floor area of the enlarged dwelling.

## Summary of provisions in the elemental method

**1.15** Diagram 1 summarises the fabric insulation standards and allowances for windows, doors and rooflights given in the Elemental method. Examples of the procedures used in this method are given in Appendices A to C. For the calculation of U-values of elements adjacent to an unheated space, see paragraph 0.8 in Section 0.

**Diagram 1 Summary of Elemental Method**

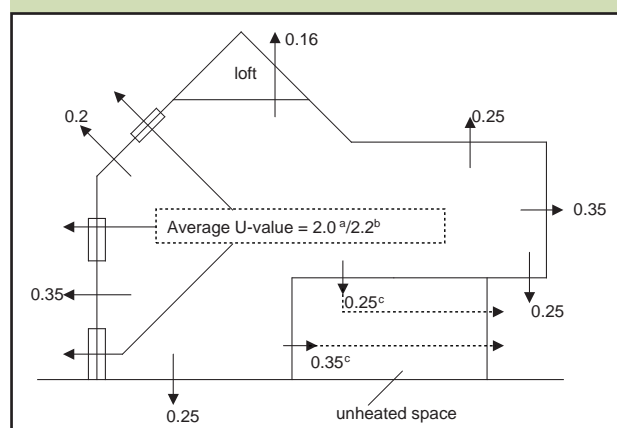

<sup>a</sup> if windows have wood or PVC frames

<sup>b</sup> if windows have metal frames

<sup>c</sup> includes the effect of the unheated space (see paragraph 0.8)

## Target U-value method for new dwellings

**1.16** Within certain limits, this method allows greater flexibility than the Elemental Method in selecting the areas of windows, doors and rooflights, and the insulation levels of individual

<sup>21</sup> Approved Document – Basements for dwellings, BCA/NHBC, 1997, ISBN 0-7210-1508-5

<sup>22</sup> SEDBUK is the Seasonal Efficiency of a Domestic Boiler in the UK, defined in The Government's Standard Assessment Procedure for the Energy Rating of Dwellings (see paragraphs 0.17-0.18).

elements in the building envelope, taking into account the efficiency of the heating system and enabling solar gain to be addressed. It can be used for any heating system. In adjusting the areas of windows, doors and rooflights, however, consideration should be given to providing satisfactory daylighting. BS 8206: Part 2<sup>23</sup> gives advice but in general total opening areas of less than 17% of the total floor area might be inadequate. The Target U-value equation given below and the associated guidance is applicable only to complete dwellings.

**1.17** The requirement would be met if the calculated average U-value of the dwelling does not exceed the Target U-value, corrected for the proposed method of heating, as determined from the following paragraphs.

**1.18** The Target U-value is determined from the following equation:

$$U_T = [0.35 - 0.19(A_R/A_T) - 0.10(A_{GF}/A_T) + 0.413(A_F/A_T)] \quad (1)$$

where:

- $U_T$  is the target U-value prior to any adjustment for heating system performance or solar gain (see paragraphs 1.20 to 1.24);
- $A_R$  is the exposed roof area;
- $A_{GF}$  is the ground floor area;
- $A_F$  is the total floor area (all storeys); and
- $A_T$  is the total area of exposed elements of the dwelling (including the ground floor).

**1.19** The total area of exposed elements should be calculated in accordance with paragraph 0.15 in Section 0.

**1.20** For dwellings to be heated by boilers with reference SEDBUK as indicated in Table 2 no adjustment to the Target U-value is necessary. Where the proposed boiler has a SEDBUK that is better or worse than the tabulated value, the Target U-value can be eased or should be tightened as appropriate by multiplying the Target U-value by the factor  $f_e$  where:

$$f_e = \frac{\text{Proposed boiler SEDBUK (\%)}}{\text{Reference boiler SEDBUK (\%)}} \quad (2)$$

and for boilers for which the SEDBUK is not available, the appropriate seasonal efficiency value from Table 4b of the SAP may be used instead (see paragraphs 0.17-0.18).

**1.21** For dwellings that are to be heated by a system other than those specified in paragraph 1.2, or if the heating system is undecided, the

Target U-value is made more demanding (i.e. improved) by dividing by a factor of 1.15 to compensate for the higher carbon emission rate.

**1.22** A solid fuel boiler should have an efficiency not less than that recommended for its type in the HETAS certification scheme.

## Optional allowance for solar gains

**1.23** For dwellings whose windows have metal frames (including thermally broken frames) the Target U-value can be increased by multiplying by a factor of 1.03, to take account of the additional solar gain due to the greater glazed proportion.

**1.24** The Target U-value equation assumes equal distribution of glazed openings on North and South elevations. Where the area of glazed openings on the South elevations exceeds that on the North, the benefit of solar heat gains can be taken into account to ease the target U-value by adding  $\Delta S$  to the target U-value, where:-

$$\Delta S = 0.04 \times [(A_S - A_N) / A_{TG}] \quad (3)$$

$A_S$  = Area of glazed openings facing south;

$A_N$  = Area of glazed openings facing north;

$A_{TG}$  = Total area of all glazed openings in the building;

and

South-facing is defined as facing South  $\pm 30^\circ$ ;

North-facing is defined as facing North  $\pm 30^\circ$ ; and

the area of glazed openings includes the area of the frames.

**1.25** If adjustments to the Target U-value are being made for heating system or window type as well as for solar gain, the adjustment for solar gain should be applied last.

**1.26** Example calculations for determining Target U-values and average U-values are given in Appendix E.

## Carbon Index method

**1.27** The aim in this method is to provide more flexibility in the design of new dwellings whilst achieving similar overall performance to that obtained by following the Elemental Method. The Carbon Index adopted in this method is defined in the SAP, and the requirement would be met if the Carbon Index for the dwelling (or each dwelling in a block of flats or converted building) is not less than 8.0. Examples of dwellings with Carbon Index of 8.0 or more are given in Appendix F.

**1.28** The edition of SAP used for the calculation of the Carbon Index should be the edition having the Secretary of State's approval

<sup>23</sup> BS 8206: Part 2 'Lighting for buildings: Code of practice for daylighting', BSI, London, 1992.



at the relevant time in the particular case (see paragraphs 0.17 and 0.18).

## Constraints when using the calculation procedures

### Poorest acceptable U-values

**1.29** When using the calculation procedures in the Target U-value and Carbon Index methods it may be possible to achieve satisfactory solutions where the U-values of some parts of elements (such as one of the walls, a part of a floor, in-gle-nooks, meter boxes or fireplace recesses) are worse than those set out in Table 1. This is provided that the poorer performance is compensated for by better performance of the other elements. However such local reductions in performance should be limited having regard for the avoidance of condensation risks on inner surfaces and within the fabric as well as the overall aim of the conservation of fuel and power. A way of achieving this would be to adopt local U-values no higher than those in Table 3.

**Table 3 Poorest U-values (W/m<sup>2</sup>K) for parts of elements acceptable as a general rule when using the Target U-value and Carbon Index Methods**

Element	Poorest acceptable U-value
Parts <sup>1</sup> of roof	0.35
Parts <sup>1</sup> of exposed wall or floor	0.7

Note  
<sup>1</sup> Whilst parts of these elements may (within the limits given in this table) have poorer U-values than those given in Table 1, it will not normally be practical to make sufficient allowances elsewhere in the design for the whole element to be built to these standards.

## Limiting thermal bridging at junctions and around openings

**1.30** The building fabric should be constructed so that there are no significant thermal bridges or gaps in the insulation layer(s) within the various elements of the fabric, at the joints between elements, and at the edges of elements such as those around window and door openings.

**1.31** A way of meeting the requirements would be to adopt the recommendations in the report on robust construction details<sup>24</sup>, which gives examples of design details and constructional practices that can deliver the required performances.

**1.32** An alternative way of meeting the requirements would be to demonstrate by calculation that the performance of the building is at least as good as it would be by following paragraph 1.31. BRE Information Paper IP 17/01<sup>25</sup> illustrates how this can be done.

## Limiting air leakage

**1.33** Reasonable provision should be made to reduce unwanted air leakage. Without prejudice to the need for compliance with all the requirements in Schedule 1, however, the need to provide for adequate ventilation for health (Part F) and adequate air for combustion appliances (Part J) should particularly be taken into account.

**1.34** Guidance on some ways of reducing infiltration is given in the report on robust construction details<sup>24</sup>. The main principle is to provide a continuous barrier to air movement around the habitable space (including separating walls and the edges of intermediate floors) that is in contact with the inside of the thermal insulation layer.

**1.35** An alternative and more quantifiable method of showing satisfactory levels of air infiltration is by pressure-testing the building following the method given in CIBSE TM 23<sup>26</sup> that the dwelling Air Permeability does not exceed 10 cubic metres per hour per square metre of external surface area at an applied pressure difference of 50 pascals.

## Space heating system controls

**1.36** The following guidance covers provisions which are appropriate for the more common varieties of heating system excluding space heating provided by individual solid fuel, gas and electric fires or room heaters. For electric storage heaters appropriate provision would be achieved by automatic charge control that detects the internal temperature and adjusts the charging of the heater accordingly.

**1.37** The requirement would be met by the appropriate provision of:

- zone controls; and
- timing controls; and
- boiler control interlocks.

<sup>24</sup> Limiting thermal bridging and air leakage: Robust construction details for dwellings and similar buildings, TSO, 2001.

<sup>25</sup> BRE IP 17/01 Assessing the effects of thermal bridging at junctions and around openings in the external elements of buildings

<sup>26</sup> TM 23:2000: Testing of buildings for air leakage, CIBSE

## Zone controls

**1.38** A way of demonstrating compliance would be (for hot water central heating systems, fan controlled electric storage heaters and electric panel heaters) to control the temperatures independently in areas (such as separate sleeping and living areas) that have different heating needs. Temperature control could be effected by room thermostats and/or thermostatic radiator valves or any other suitable temperature sensing devices, together with appropriate control devices.

**1.39** In most dwellings one timing zone divided into two temperature control sub-zones would be appropriate. However in single-storey open-plan flats and bed-sitters, for example, sub-zoning of temperature control could be inappropriate. Reasonable provision in the case of large dwellings of more than 150m<sup>2</sup> floor area, would be for no zone to have an area exceeding 150m<sup>2</sup> and the operation of the heating to be separately timed in each zone.

## Timing controls

**1.40** Timing devices should be provided to control the periods when the heating systems operate. This provision should be made for gas fired and oil fired systems and for systems with solid fuel fired boilers where forced-draught fans operate when heat is required. Timing systems would be inappropriate for systems with solid fuel boilers which operate only by natural draught. Separate timing control should be provided for space heating and water heating, except for combination boilers or solid fuel appliances.

## Boiler control interlocks

**1.41** Gas and oil fired hot water central heating system controls should switch the boiler off when no heat is required whether control is by room thermostats or by thermostatic radiator valves:

- a) The boiler in systems controlled by thermostats should operate only when a space heating or vessel thermostat is calling for heat.
- b) Where it is proposed to effect control by thermostatic radiator valves, a room thermostat (or other device such as a flow switch) should also be provided to switch off the boiler when there is no demand for heating or hot water.

## Hot Water Systems

**1.42** There are several acceptable ways of providing hot water systems in dwellings. The guidance in this document is for systems incorporating hot water storage.

**1.43** For systems incorporating integral or separate hot water storage vessels, ways of meeting the requirement include:

- a) arranging for hot water storage systems to meet the insulation requirements of BS 1566, BS 699, BS 3198, or BS 7206 (as appropriate); or
- b) in ordinary cases, insulating vessels with a 35mm thick, factory-applied coating of PU-foam having a minimum density of 30kg/m<sup>3</sup>. (For unvented hot water systems additional insulation should be provided to control the heat losses through the safety fittings and pipework but without impeding safe operation and visibility of warning discharges. (See Approved Document G.)

**1.44** Provisions should enable efficient operation without excessive boiler firing and primary circuit losses. A way of demonstrating compliance for indirectly heated hot water storage systems would be for the size of the heat exchanger to be at least that recommended in BS 1566, BS 3198, or BS 7206 (as appropriate) and for them to be served by a pumped primary system.

**1.45** A way of demonstrating compliance for primary storage systems would be to meet the requirements of the 1999 WMA performance specifications for thermal stores<sup>27</sup>.

## Alternative approach for space heating and HWS system controls

**1.46** The requirement would be met by adopting the relevant recommendations in BS 5864<sup>28</sup> or Good Practice Guide 302<sup>29</sup> provided that they include zoning, timing and interlock features similar to the above.

## Commissioning of heating and HWS systems

**1.47** Heating and HWS systems should be inspected at completion of installation so as to establish that the specified and approved

<sup>27</sup> Performance specification for thermal stores, Waterheater Manufacturers Association, 1999

<sup>28</sup> BS 5864:1989 Specification for installation in domestic premises of gas-fired ducted air heaters of rated output not exceeding 60 kW

<sup>29</sup> GPG 302 (2001): Controls for Domestic Central Heating and Hot Water, BRECSU.

provisions for efficient operation have been put in place. Without prejudice to the need to comply with health and safety requirements, these systems should be commissioned to make reasonably certain they can operate efficiently for the purposes of the conservation of fuel and power.

**1.48** Commissioning means the advancement of these systems from the state of static completion to working order to the specifications relevant to achieving compliance with Part L, without prejudice to the need to comply with health and safety requirements. For each system it includes setting-to-work, regulation (that is testing and adjusting repetitively) to achieve the specified performance, the calibration, setting up and testing of the associated automatic control systems, and recording of the system settings and the performance test results that have been accepted as satisfactory.

**1.49** Responsibility for achieving compliance with the requirements of Part L rests with the person carrying out the work. That “person” may be, e.g., a developer or main contractor who has directly carried out the work subject to Part L, or engaged a subcontractor to carry it out; or a specialist firm directly engaged by a private client. The person responsible for achieving compliance should either themselves provide a certificate, or obtain a certificate from the sub-contractor, that commissioning has been successfully carried out. The certificate should be made available to the client and the building control body. Where the person giving the certificate has a recognised qualification, the certificate may be accepted by the building control body as evidence that the relevant requirements in Part L1 b) and d) have been complied with. If there is no relevant qualification, or if a suitably qualified certifier is not available, the person responsible for carrying out the work should nevertheless provide or obtain a written declaration of successful commissioning and make it available to the client and the building control body.

**1.50** A suitable commissioning certificate would be the one published as part of the Benchmark<sup>30</sup> Code of Practice for the Installation, Commissioning and Servicing of Central Heating Systems, a blank copy of which may be included with the boiler manufacturer’s installation instructions.

## Operating and Maintenance instructions for heating and hot water systems

**1.51** The building owner and/or occupier should be given information on the operation and maintenance of the heating and hot water

systems. A way of complying would be to provide a suitable set of operating and maintenance instructions in an accessible format in each new dwelling, and whenever the systems in an existing dwelling are substantially altered. The instructions should be directly related to the system(s) in the dwelling. Without prejudice to the need to comply with health and safety requirements, the instructions should explain to householders how to operate the systems so that they can perform efficiently, and what routine maintenance is advisable for the purposes of the conservation of fuel and power.

## Insulation of pipes and ducts

**1.52** Reasonable provision should be made for insulating pipes and ducts to conserve heat and hence maintain the temperature of the water or air heating service, and in the case of HWS systems to avoid excessive losses between useful draw-offs. Some ways of meeting the requirement comprise:-

- a) wrapping space heating pipe work located outside the building fabric insulation layer(s) with insulation material having a thermal conductivity at 40°C not exceeding 0.035 W/m·K and a thickness equal to the outside diameter of the pipe up to a maximum of 40mm; or
- b) for pipes and in the case of warm air ducts providing insulation in accordance with the recommendations of BS 5422:2001, Methods for specifying thermal insulation materials on pipes, ductwork and equipment in the temperature range -40°C to +700°C; and
- c) insulating the hot pipes connected to hot water storage vessels, including the vent pipe, and the primary flow and return to the heat exchanger, where fitted, to the standard in b) above for at least 1 metre from their points of connection (or they should be insulated up to the point where they become concealed).

**1.53** It should be noted that central heating and hot water pipe work in unheated areas may need increased insulation thicknesses for the purpose of protection against freezing. Guidance on suitable protection measures is given in BRE Report No 262 Thermal insulation: avoiding risks, 2002 Edition.

## Internal Lighting

**1.54** Reasonable provision should be made for dwelling occupiers to obtain the benefits of efficient lighting. A way of showing compliance with the requirement would be to provide at a reasonable number of locations, where lighting

<sup>30</sup> Benchmark is administered by the Central Heating Information Council, tel: 01926 423284

can be expected to have most use, fixed lighting (comprising either basic lighting outlets or complete luminaires) that only take lamps having a luminous efficacy greater than 40 lumens per circuit-watt. Circuit-watts means the power consumed in lighting circuits by lamps and their associated control gear and power factor correction equipment. Examples of lamps that achieve this efficacy include fluorescent tubes and compact fluorescent lamps (not GLS tungsten lamps with bayonet cap or Edison screw bases).

**1.55** Guidance on identifying suitable locations for efficient lighting is given in General Information Leaflet GIL 20<sup>31</sup>. A way of establishing how many locations to equip for efficient lighting would be to follow the recommendations in Table 4.

**1.56** When considering reasonable provision for lighting, for a new dwelling with an integral

**Table 4 Method for determining the number of locations to be equipped as a reasonable provision for efficient lighting**

Number of rooms created <sup>1</sup>	Recommended minimum number of locations <sup>2</sup>
1-3	1
4-6	2
7-9	3
10-12	4

Notes  
<sup>1</sup> Hall, stairs and landing(s) count as one room (but may contain more than one fitting)  
<sup>2</sup> Excludes garages, lofts and outhouses

conservatory, the conservatory should be counted as a room. In other cases, the conservatory can be excluded from the method in Table 4.

## External lighting fixed to the building

**1.57** External lighting includes lighting in porches, but not lighting in garages and carports. When providing external lighting, reasonable provision should be made to enable effective control and/or the use of efficient lamps. A way of showing compliance when providing external lighting would be to install systems that:

- a) automatically extinguish when there is enough daylight, and when not required at night; or
- b) have sockets that can only be used with lamps having an efficacy greater than 40 lumens per circuit Watt (such as fluorescent or compact fluorescent lamp types, and not GLS tungsten lamps with bayonet cap or Edison screw bases).

## Conservatories

**1.58** For the purposes of the guidance in Part L, a conservatory has not less than three-quarters of the area of its roof and not less than one half of the area of its external walls made of translucent material.

**1.59** When a conservatory is attached to and built as part of a new dwelling:

- a) Where there is no separation between the conservatory and the dwelling, the conservatory should be treated as an integral part of the dwelling;
- b) Where there is separation between the conservatory and the dwelling, energy savings can be achieved if the conservatory is not heated. If fixed heating installations are proposed, however, they should have their own separate temperature and on/off controls.

**1.60** When a conservatory is attached to an existing dwelling and an opening is enlarged or newly created as a material alteration, reasonable provision should be made to enable the heat loss from the dwelling to be limited. Ways of meeting the requirement would be:

- a) to retain the existing separation where the opening is not to be enlarged; or
- b) to provide separation as or equivalent to windows and doors having the average U-value given in Table 1 where the opening is to be newly created or enlarged.

**1.61** For the purposes of satisfying the requirements for the conservation of fuel and power, separation between a dwelling and a conservatory means:

- a) Separating walls and floors insulated to at least the same degree as the exposed walls and floors;
- b) Separating windows and doors with the same U-value and draught-stripping provisions as the exposed windows and doors elsewhere in the dwelling.

**1.62** Attention is drawn to the safety requirements of Part N of the Building Regulations regarding conservatory glazing.

<sup>31</sup> GIL 20, 1995: Low energy domestic lighting, BRESCU

## Section 2: Work on existing dwellings

### Replacement of controlled services or fittings

**2.1** “Controlled Service or fitting” is defined in Regulation 2(1) of the Building Regulations 2000 (as amended by the Building (Amendment) Regulations 2001) as “a service or fitting in relation to which Part G, H, J or L of Schedule 1 imposes a requirement;”.

**2.2** The definition of building work in Regulation 3(1) includes the provision or extension of a controlled service or fitting in or in connection with a building. This is qualified in Regulation 3(1A) as follows:

*“The provision or extension of a controlled service or fitting –*

- (a) in or in connection with an existing dwelling; and*
- (b) being a service or fitting in relation to which paragraph L1, but not Part G, H or J, of Schedule 1 imposes a requirement,*

*shall only be building work where that work consists of the provision of a window, rooflight, roof window, door (being a door which together with its frame has more than 50 per cent of its internal face area glazed), a space heating or hot water service boiler, or a hot water vessel.”*

**2.3** Reasonable provision where undertaking replacement work on controlled services or fittings (whether replacing with new but identical equipment or with different equipment and whether the work is solely in connection with controlled services or includes work on them) depends on the circumstances in the particular case and would also need to take account of historic value (see paragraph 2.9 *et seq*). Possible ways of satisfying the requirements include the following:-

- a) **Windows, doors and rooflights.** Where these elements are to be replaced, providing new draught-proofed ones either with an average U-value not exceeding the appropriate entry in Table 1, or with a centre-pane U-value not exceeding 1.2 W/m<sup>2</sup>K (the requirement does not apply to repair work on parts of these elements, such as replacing broken glass or sealed double-glazing units or replacing rotten framing members). The replacement work should comply with the requirements of Parts L and N. In addition the building should not have a worse level of compliance, after the work, with other applicable Parts of Schedule 1. These may include Parts B, F and J.
- b) **Heating boilers.** Where heating boilers are to be replaced in dwellings having a floor area greater than 50m<sup>2</sup>, providing a new boiler as if for a new dwelling i.e:-

(1) in the case of ordinary oil or gas boilers, providing a boiler with a SEDBUK not less than the appropriate entry in Table 2<sup>32</sup>, together with appropriate controls following the guidance starting at paragraph 1.36. (In the case of replacement boilers installed in the period up to 31 August 2002, it would be reasonable to provide a less efficient boiler provided the heating controls comply with specification HR2 or HC2 given in GIL 59<sup>33</sup>;

(2) in the case of back boilers, providing a boiler having a SEDBUK of not less than three percentage points lower than the appropriate entry in Table 2;

(3) in the case of solid fuel boilers, providing a boiler having an efficiency not less than that recommended for its type in the HETAS certification scheme.

c) **Hot water vessels.** When replacing hot water vessels, reasonable provision would be to provide new equipment as if for a new dwelling following the guidance beginning at paragraph 1.43.

d) **Boiler and hot water storage controls.** So that replacement boilers (other than solid fuel boilers) and hot water vessels can achieve reasonable seasonal efficiency, the work may also need to include replacement of the time switch or programmer, room thermostat, and hot water vessel thermostat, and provision of a boiler interlock and fully pumped circulation. Section 3 of GPG 302<sup>34</sup> gives more advice on how this can be done.

e) As an alternative to a) to d), following the guidance in, for example, GPG 155<sup>35</sup> may be acceptable provided that an equivalent improvement in the dwelling’s Carbon Index is achieved.

f) **Commissioning and providing operating and maintenance instructions.** Where heating and hot water systems are to be altered as in paragraphs (a) to (e), reasonable provision would also include appropriate commissioning and the provision of operating and maintenance instructions following the guidance in paragraphs 1.47 to 1.51.

<sup>32</sup> For boilers for which the SEDBUK is not available, the appropriate seasonal efficiency value from Table 4b of the SAP may be used instead (see paragraphs 0.17-0.18).

<sup>33</sup> GIL 59, 2000: Central Heating system specifications (CheSS).

<sup>34</sup> GPG 302, 2001: Controls for domestic central heating and hot water, BRECSU.

<sup>35</sup> GPG 155, 2001: Energy efficient refurbishment of existing housing, BRECSU.

## Material alterations

**2.4** “Material alterations” are defined in Regulation 3(2) as follows.

*“An alteration is material for the purposes of these Regulations if the work, or any part of it, would at any stage result –*

- (a) in a building or controlled service or fitting not complying with a relevant requirement where previously it did; or*
- (b) in a building or controlled service or fitting which before the work commenced did not comply with a relevant requirement, being more unsatisfactory in relation to such a requirement.”*

**2.5** “Relevant requirement” is defined in Regulation 3(3) as follows.

*“In paragraph (2) “relevant requirement” means any of the following applicable requirements of Schedule 1, namely –*

*Part A (structure)*

*Paragraph B1 (means of warning and escape)*

*Paragraph B3 (internal fire spread – structure)*

*Paragraph B4 (external fire spread)*

*Paragraph B5 (access and facilities for the fire service)*

*Part M (access and facilities for disabled people).”*

**2.6** Reasonable provision where undertaking material alterations depends on the circumstances in the particular case and would need to take account of historic value (see paragraph 2.9 *et seq*). Without prejudice to the need for compliance with all the requirements in Schedule 1, the need to comply with the requirements of Parts F and J should particularly be taken into account. Possible ways of satisfying the requirements include:

- a) **Roof insulation.** When substantially replacing any of the major elements of a roof structure in a material alteration, providing insulation to achieve the U-value for new dwellings.
- b) **Floor insulation.** Where the structure of a ground floor or exposed floor is to be substantially replaced, or re-boarded, providing insulation in heated rooms to the standard for new dwellings.
- c) **Wall insulation.** When substantially replacing complete exposed walls or their external renderings or cladding or internal surface finishes, or the internal surfaces of separating walls to unheated spaces, providing a reasonable thickness of insulation.
- d) **Sealing measures.** When carrying out any of the above work, including reasonable sealing measures to improve airtightness. Without prejudice to the need for compliance with all

the requirements in Schedule 1 however, the need to comply with the requirements of Parts F and J should particularly be taken into account.

e) **Controlled services and fittings.** When replacing controlled services and fittings, following the guidance in paragraph 2.3.

## Material changes of use

**2.7** Material changes of use are defined in Regulation 5 as follows.

*“..... for the purposes of these Regulations, there is a material change of use where there is a change in the purposes for which or the circumstances in which a building is used, so that after that change -*

*(a) the building is used as a dwelling, where previously it was not;*

*(b) the building contains a flat, where previously it did not;*

*(c) the building is used as an hotel or a boarding house, where previously it was not;*

*(d) the building is used as an institution, where previously it was not;*

*(e) the building is used as a public building, where previously it was not;*

*(f) the building is not a building described in Classes I to VI in Schedule 2, where previously it was; or*

*(g) the building, which contains at least one dwelling, contains a greater or lesser number of dwellings than it did previously.”*

**2.8** Regulation 6 includes the paragraphs in Part L of Schedule 1 as amongst those that apply when works comprising a change of use are undertaken. Reasonable provision where undertaking a material change of use depends on the circumstances in each particular case and would need to take account of historic value (see paragraph 2.9). Without prejudice to the need for compliance with all the requirements in Schedule 1, the need to comply with the requirements of Parts F and J should particularly be taken into account. Possible ways of satisfying the requirement include:

a) **Accessible lofts.** When upgrading insulation in accessible lofts, providing additional insulation to achieve a U-value not exceeding 0.25 W/m<sup>2</sup>K where the existing insulation provides a U-value worse than 0.35 W/m<sup>2</sup>K.

b) **Roof insulation.** When substantially replacing any of the major elements of a roof structure, providing insulation to achieve the U-value considered reasonable for new dwellings.

- c) **Floor insulation.** When substantially replacing the structure of a ground floor, providing insulation in heated rooms to the standard for new dwellings.
- d) **Wall insulation.** When substantially replacing complete exposed walls or their internal or external renderings or plaster finishes or the internal renderings and plaster of separating walls to an unheated space, providing a reasonable thickness of insulation.
- e) **Sealing measures.** When carrying out any of the above work, including reasonable sealing measures to improve airtightness. Without prejudice to the need for compliance with all the requirements in Schedule 1, however, the need to comply with the requirements of Parts F and J should particularly be taken into account.
- f) **Lighting.** Providing lighting in accordance with the guidance in paragraphs 1.54 to 1.57.
- g) **Controlled services and fittings.** When replacing controlled services and fittings, following the guidance in paragraph 2.3.
- b) rebuilding a former historic building (e.g. following a fire or filling in a gap site in a terrace;
- c) making provisions enabling the fabric of historic buildings to “breathe” to control moisture and potential long term decay problems<sup>37</sup>.

## Historic buildings

**2.9** Historic buildings include -

- a) listed buildings,
- b) buildings situated in conservation areas,
- c) buildings which are of architectural and historical interest and which are referred to as a material consideration in a local authority’s development plan,
- d) buildings of architectural and historical interest within national parks, areas of outstanding natural beauty, and world heritage sites.

**2.10** The need to conserve the special characteristics of such historic buildings needs to be recognised<sup>36</sup>. In such work, the aim should be to improve energy efficiency where and to the extent that it is practically possible, always provided that the work does not prejudice the character of the historic building, or increase the risk of long-term deterioration to the building fabric or fittings. In arriving at an appropriate balance between historic building conservation and energy conservation, it would be appropriate to take into account the advice of the local planning authority’s conservation officer.

**2.11** Particular issues relating to work in historic buildings that warrant sympathetic treatment and where advice from others could therefore be beneficial include –

- a) restoring the historic character of a building that had been subject to previous inappropriate alteration, eg replacement windows, doors and rooflights;

<sup>36</sup> BS 7913 *The principles of the conservation of historic buildings*, BSI, 1998 provides guidance on the principles that should be applied when proposing work on historic buildings.

<sup>37</sup> The need for old buildings to breathe, SPAB Information sheet 4, 1986.

# Appendix A: Tables of U-Values

## Contents

### Tables

#### Windows, doors and rooflights

Table A1: Indicative U-values for windows and rooflights with wood or PVC-U frames, and doors 23

Table A2: Indicative U-values for windows with metal frames 24

Table A3: Adjustments to U-values in Table A2 for frames with thermal breaks 24

#### Corrections to U-values of roofs, walls and floors

Table A4: Corrections to U-values 25

#### Roofs

Table A5: Base thickness of insulation between ceiling joists or rafters 25

Table A6: Base thickness of insulation between and over joists or rafters 25

Table A7: Base thickness for continuous insulation 26

Table A8: Allowable reduction in base thickness for common roof components 26

#### Walls

Table A9: Base thickness of insulation layer 29

Table A10: Allowable reductions in base thickness for common components 29

Table A11: Allowable reductions in base thickness for concrete components 29

Table A12: Allowable reductions in base thickness for insulated timber framed walls 29

#### Ground floors

Table A13: Insulation thickness for solid floors in contact with the ground 32

Table A14: Insulation thickness for suspended timber ground floors 32

Table A15: Insulation thickness for suspended concrete beam and block ground floors 33

#### Upper floors

Table A16: Upper floors of timber construction 34

Table A17: Upper floors of concrete construction 34

Table A18: Upper floors: allowable reductions in base thickness for common components 34

#### Building materials 34

Table A19: Thermal conductivity of some common building materials 34

Note: The values in these tables have been derived using the combined method, taking into account the effects of thermal bridging where appropriate. Intermediate values can be obtained from the tables by linear interpolation. As an alternative to using these tables, the procedures in Appendices B and C can be used to obtain a more accurate calculation of the thickness of insulation required.

### Example calculations

Note: the examples are offered as indicating ways of meeting the requirements of Part L but designers also have to ensure that their designs comply with all the other parts of Schedule 1 to the Building Regulations.

PAGE

#### Roofs

Example 1: Pitched roof with insulation between ceiling joists or between rafters 27

Example 2: Pitched roof with insulation between and over ceiling joists 28

Example 3: Concrete deck roof 28

#### Walls

Example 4: Masonry cavity wall with internal insulation 30

Example 5: Masonry cavity wall (tied with vertical-twist stainless-steel ties) filled with insulation with plasterboard on dabs 30

Example 6: Masonry wall (tied with vertical-twist stainless-steel ties) with partial cavity-fill 31

Example 7: Timber-framed wall 31

#### Ground floors 32

Example 8: Solid floor in contact with the ground 33

Example 9: Suspended timber floor 33



## Windows, doors and rooflights

The following tables provide indicative U-values for windows, doors and rooflights. Table A1 applies to windows and rooflights with wood or PVC-U frames. Table A2 applies to windows with metal frames, to which (if applicable) the adjustments for thermal breaks and rooflights in Table A3 should be applied. The tables do not apply to curtain walling or to other structural glazing not fitted in a frame. For the purposes of this Approved Document a roof window may be considered as a rooflight.

The U-value of a window or rooflight containing low-E glazing is influenced by the emissivity,  $\epsilon_n$ ,

of the low-E coating. Low-E coatings are of two principal types, known as 'hard' and 'soft'. Hard coatings generally have emissivities in the range 0.15 to 0.2, and the data for  $\epsilon_n = 0.2$  should be used for hard coatings, or if the glazing is stated to be low-E but the type of coating is not specified. Soft coatings generally have emissivities in the range 0.05 to 0.1. The data for  $\epsilon_n = 0.1$  should be used for a soft coating if the emissivity is not specified.

When available, manufacturers' certified U-values (by measurement or calculation according to the standards given in Section 0) should be used in preference to the data given in these tables.

**Table A1 Indicative U-values (W/m<sup>2</sup>·K) for windows and rooflights with wood or PVC-U frames, and doors**

	Gap between panes			Adjustment for rooflights in dwellings <sup>3</sup>
	6mm	12mm	16mm or more	
Single glazing	4.8			+0.3
Double glazing (air filled)	3.1	2.8	2.7	+0.2
Double glazing (low-E, $\epsilon_n = 0.2$ ) <sup>1</sup>	2.7	2.3	2.1	
Double glazing (low-E, $\epsilon_n = 0.15$ )	2.7	2.2	2.0	
Double glazing (low-E, $\epsilon_n = 0.1$ )	2.6	2.1	1.9	
Double glazing (low-E, $\epsilon_n = 0.05$ )	2.6	2.0	1.8	
Double glazing (argon filled) <sup>2</sup>	2.9	2.7	2.6	
Double glazing (low-E $\epsilon_n = 0.2$ , argon filled)	2.5	2.1	2.0	
Double glazing (low-E $\epsilon_n = 0.1$ , argon filled)	2.3	1.9	1.8	
Double glazing (low-E $\epsilon_n = 0.05$ , argon filled)	2.3	1.8	1.7	
Triple glazing	2.4	2.1	2.0	
Triple glazing (low-E, $\epsilon_n = 0.2$ )	2.1	1.7	1.6	
Triple glazing (low-E, $\epsilon_n = 0.1$ )	2.0	1.6	1.5	
Triple glazing (low-E, $\epsilon_n = 0.05$ )	1.9	1.5	1.4	
Triple glazing (argon filled)	2.2	2.0	1.9	
Triple glazing (low-E $\epsilon_n = 0.2$ , argon filled)	1.9	1.6	1.5	
Triple glazing (low-E $\epsilon_n = 0.1$ , argon filled)	1.8	1.4	1.3	
Triple glazing (low-E $\epsilon_n = 0.05$ , argon filled)	1.7	1.4	1.3	
Solid wooden door <sup>4</sup>	3.0			

Notes

<sup>1</sup> The emissivities quoted are normal emissivities. (Corrected emissivity is used in the calculation of glazing U-values.) Uncoated glass is assumed to have a normal emissivity of 0.89.

<sup>2</sup> The gas mixture is assumed to consist of 90% argon and 10% air.

<sup>3</sup> No correction need be applied to rooflights in buildings other than dwellings.

<sup>4</sup> For doors which are half-glazed the U-value of the door is the average of the appropriate window U-value and that of the non-glazed part of the door (e.g. 3.0 W/m<sup>2</sup>·K for a wooden door).

**Table A2 Indicative U-values (W/m<sup>2</sup>·K) for windows with metal frames (4mm thermal break)**

	gap between panes		
	6mm	12mm	16mm or more
Single glazing	5.7		
Double glazing (air filled)	3.7	3.4	3.3
Double glazing (low-E, $\epsilon_n = 0.2$ )	3.3	2.8	2.6
Double glazing (low-E, $\epsilon_n = 0.1$ )	3.2	2.6	2.5
Double glazing (low-E, $\epsilon_n = 0.05$ )	3.1	2.5	2.3
Double glazing (argon filled)	3.5	3.3	3.2
Double glazing (low-E, $\epsilon_n = 0.2$ , argon filled)	3.1	2.6	2.5
Double glazing (low-E, $\epsilon_n = 0.1$ , argon filled)	2.9	2.4	2.3
Double glazing (low-E, $\epsilon_n = 0.05$ , argon filled)	2.8	2.3	2.1
Triple glazing	2.9	2.6	2.5
Triple glazing (low-E, $\epsilon_n = 0.2$ )	2.6	2.2	2.0
Triple glazing (low-E, $\epsilon_n = 0.1$ )	2.5	2.0	1.9
Triple glazing (low-E, $\epsilon_n = 0.05$ )	2.4	1.9	1.8
Triple glazing (argon-filled)	2.8	2.5	2.4
Triple glazing (low-E, $\epsilon_n = 0.2$ , argon filled)	2.4	2.0	1.9
Triple glazing (low-E, $\epsilon_n = 0.1$ , argon filled)	2.2	1.9	1.8
Triple glazing (low-E, $\epsilon_n = 0.05$ , argon filled)	2.2	1.8	1.7

Note

For windows and rooflights with metal frames incorporating a thermal break other than 4mm, the following adjustments should be made to the U-values given in Table A2.

**Table A3 Adjustments to U-values in Table A2 for frames with thermal breaks**

Thermal break (mm)	Adjustment to U-value (W/m <sup>2</sup> ·K)	
	Window, or rooflight in building other than a dwelling	Rooflight in dwellings
0 (no break)	+0.3	+0.7
4	+0.0	+0.3
8	-0.1	+0.2
12	-0.2	+0.1
16	-0.2	+0.1

Note

Where applicable adjustments for both thermal break and rooflight should be made. For intermediate thicknesses of thermal breaks, linear interpolation may be used.

# Corrections to U-values of roofs, walls and floors

Annex D of BS EN ISO 6946 provides corrections to U-values to allow for the effects of:

- air gaps in insulation
- mechanical fasteners penetrating the insulation layer
- precipitation on inverted roofs.

The corrected U-value ( $U_c$ ) is obtained by adding a correction term  $\Delta U$ :

$$U_c = U + \Delta U$$

Table A4 gives the values of  $\Delta U$  for some typical constructions.

If the total  $\Delta U$  is less than 3% of  $U$  then the corrections need not be applied and  $\Delta U$  can be taken to be zero. However, where corrections are to be applied, before using the following tables the following steps should be carried out:-

- 1) subtract  $\Delta U$  from the desired U-value.
- 2) use this adjusted U-value in the tables when calculating the required thickness of insulation.

This thickness of insulation then meets the original desired U-value, having allowed for the  $\Delta U$  correction(s).

# Roofs

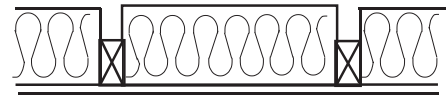
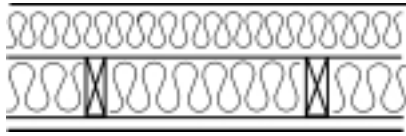

**Table A5 Base thickness of insulation between ceiling joists or rafters**

Design U-value (W/m²K)	Thermal conductivity of insulant (W/m·K)							
	0.020	0.025	0.030	0.035	0.040	0.045	0.050	
	Base thickness of insulating material (mm)							
	A	B	C	D	E	F	G	H
1	0.15	371	464	557	649	742	835	928
2	0.20	180	224	269	314	359	404	449
3	0.25	118	148	178	207	237	266	296
4	0.30	92	110	132	154	176	198	220
5	0.35	77	91	105	122	140	157	175
6	0.40	67	78	90	101	116	130	145

**Table A4 Corrections to U-values**

Roofs	$\Delta U$ (W/m²K)
Insulation fixed with nails or screws	0.02
Insulation between joists or rafters	0.01
Insulation between and over joists or rafters	0.00
Walls	
Timber frame where the insulation partly fills the space between the studs	0.04
Timber frame where the insulation fully fills the space between the studs	0.01
Internal insulation fixed with nails or screws which penetrate the insulation	0.02
External insulation with metal fixings that penetrate the insulation	0.02
Insulated cavity wall with cavity greater than 75mm and tied with steel vertical-twist ties	0.02
Insulated cavity wall with a cavity less than or equal to 75mm tied with ties other than steel vertical-twist ties	0.00
Floors	
Suspended timber floor with insulation between joists	0.04
Floor insulation fixed with nails or screws	0.02

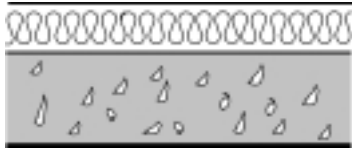

**Table A6 Base thickness of insulation between and over joists or rafters**

Thermal conductivity of insulant (W/m-K)  
0.020 0.025 0.030 0.035 0.040 0.045 0.050

Design U-value (W/m <sup>2</sup> K)	Base thickness of insulating material (mm)							
	A	B	C	D	E	F	G	H
1	0.15	161	188	217	247	277	307	338
2	0.20	128	147	167	188	210	232	255
3	0.25	108	122	137	153	170	187	205
4	0.30	92	105	117	130	143	157	172
5	0.35	77	91	103	113	124	136	148
6	0.40	67	78	90	101	110	120	130

Note  
Tables A5 and A6 are derived for roofs with the proportion of timber at 8%, corresponding to 48mm wide timbers at 600mm centres, excluding noggings. For other proportions of timber the U-value can be calculated using the procedure in Appendix B.



**Table A7 Base thickness for continuous insulation**

Thermal conductivity of insulant (W/m-K)  
0.020 0.025 0.030 0.035 0.040 0.045 0.050

Design U-value (W/m <sup>2</sup> K)	Base thickness of insulating material (mm)							
	A	B	C	D	E	F	G	H
1	0.15	131	163	196	228	261	294	326
2	0.20	97	122	146	170	194	219	243
3	0.25	77	97	116	135	154	174	193
4	0.30	64	80	96	112	128	144	160
5	0.35	54	68	82	95	109	122	136
6	0.40	47	59	71	83	94	106	118

**Table A8 Allowable reduction in base thickness for common roof components**

Thermal conductivity of insulant (W/m-K)  
0.020 0.025 0.030 0.035 0.040 0.045 0.050

	Concrete slab density (kg/m <sup>3</sup> )	Reduction in base thickness of insulation for each 100mm of concrete slab							
		A	B	C	D	E	F	G	H
1	600	10	13	15	18	20	23	25	
2	800	7	9	11	13	14	16	18	
3	1100	5	6	8	9	10	11	13	
4	1300	4	5	6	7	8	9	10	
5	1700	2	2	3	3	4	4	5	
6	2100	1	2	2	2	3	3	3	

	Other materials and components	Reduction in base thickness of insulating material (mm)							
		A	B	C	D	E	F	G	H
7	10mm plasterboard	1	2	2	2	3	3	3	
8	13mm plasterboard	2	2	2	3	3	4	4	
9	13mm sarking board	2	2	3	3	4	4	5	
10	12mm calcium silicate liner board	1	2	2	2	3	3	4	
11	Roof space (pitched)	4	5	6	7	8	9	10	
12	Roof space (flat)	3	4	5	6	6	7	8	
13	19mm roof tiles	0	1	1	1	1	1	1	
14	19mm asphalt (or 3 layers of felt)	1	1	1	1	2	2	2	
15	50mm screed	2	3	4	4	5	5	6	



**Example 2: Pitched roof with insulation between and over ceiling joists**

Determine the thickness of the insulation layer above the joists required to achieve a U-value of 0.20 W/m<sup>2</sup>K for the roof construction shown below:

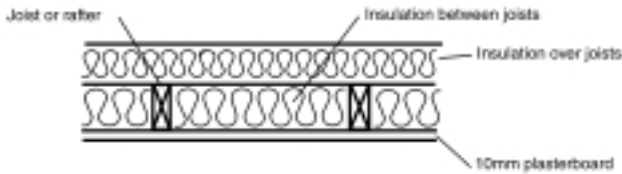

It is proposed to use mineral wool insulation between and over the joists with a thermal conductivity of 0.04 W/m·K.

Using Table A6:

From **column F, row 2** of the table, the base thickness of insulation layer = 210mm.

The base thickness may be reduced by taking account of the other materials as follows:

From Table A8:

- 19mm roof tiles **column F, row 13** = 1mm
- Roofspace (pitched) **column F, row 11** = 8mm
- 10mm plasterboard **column F, row 7** = 3mm
- Total reduction = 12mm

The minimum thickness of the insulation layer over the joists, required in addition to the 100mm insulation between the joists, to achieve a U-value of 0.20 W/m<sup>2</sup>K is therefore:

*Base thickness less total reduction*  
 ie 210 – 100 – 12 = **98mm**.

**Example 3: Concrete deck roof**

Determine the thickness of the insulation layer required to achieve a U-value of 0.25 W/m<sup>2</sup>K for the roof construction shown below.

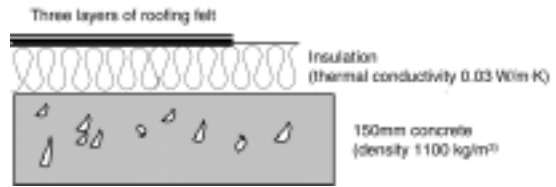

Using Table A7:

From **column D, row 3** of the table, the base thickness of the insulation layer is 116mm.

The base thickness may be reduced by taking account of the other materials as follows:

From Table A8:

- 3 layers of felt **column D, row 14** = 1mm
- 150mm concrete deck **column D, row 3**  
 adjusted for 150mm thickness (1.5 x 8) = 12mm
- Total reduction = 13mm

The minimum thickness of the insulation layer required to achieve a U-value of 0.25 W/m<sup>2</sup>K is therefore:

*Base thickness less total reduction*  
 i.e. 116 – 13 = **103mm**.

# Walls

**Table A9 Base thickness of insulation layer**

Design U-value (W/m <sup>2</sup> K)	Thermal conductivity of insulant (W/m·K) 0.020 0.025 0.030 0.035 0.040 0.045 0.050							
	Base thickness of insulating material (mm)							
	A	B	C	D	E	F	G	H
1	0.20	97	121	145	169	193	217	242
2	0.25	77	96	115	134	153	172	192
3	0.30	63	79	95	111	127	142	158
4	0.35	54	67	81	94	107	121	134
5	0.40	47	58	70	82	93	105	117
6	0.45	41	51	62	72	82	92	103

**Table A10 Allowable reductions in base thickness for common components**

Component	Thermal conductivity of insulant (W/m·K) 0.020 0.025 0.030 0.035 0.040 0.045 0.050							
	Reduction in base thickness of insulating material (mm)							
	A	B	C	D	E	F	G	H
1 Cavity (25mm or more)	4	5	5	6	7	8	8	9
2 Outer leaf brickwork	3	3	4	5	5	6	6	6
3 13mm plaster	1	1	1	1	1	1	1	1
4 13mm lightweight plaster	2	2	2	3	3	4	4	4
5 9.5mm plasterboard	1	2	2	2	3	3	3	3
6 12.5mm plasterboard	2	2	2	3	3	4	4	4
7 Airspace behind plasterboard drylining	2	3	4	4	5	5	6	6
8 9mm sheathing ply	1	2	2	2	3	3	3	3
9 20mm cement render	1	1	1	1	2	2	2	2
10 13mm tile hanging	0	0	0	1	1	1	1	1

**Table A11 Allowable reductions in base thickness for concrete components**

Density (kg/m <sup>3</sup> )	Thermal conductivity of insulant (W/m·K) 0.020 0.025 0.030 0.035 0.040 0.045 0.050							
	Reduction in base thickness of insulation (mm) for each 100mm of concrete							
	A	B	C	D	E	F	G	H
Concrete blockwork inner leaf								
1 600	9	11	13	15	17	20	22	22
2 800	7	9	10	12	14	16	17	17
3 1000	5	6	8	9	10	11	13	13
4 1200	4	5	6	7	8	9	10	10
5 1400	3	4	5	6	7	8	8	8
6 1600	3	3	4	5	6	6	7	7
7 1800	2	2	3	3	4	4	4	4
8 2000	2	2	2	3	3	3	4	4
9 2400	1	1	2	2	2	2	3	3
Concrete blockwork outer leaf or single leaf wall								
10 600	8	11	13	15	17	19	21	21
11 800	7	9	10	12	14	15	17	17
12 1000	5	6	7	8	10	11	12	12
13 1200	4	5	6	7	8	9	10	10
14 1400	3	4	5	6	6	7	8	8
15 1600	3	3	4	5	5	6	7	7
16 1800	2	2	3	3	3	4	4	4
17 2000	1	2	2	3	3	3	4	4
18 2400	1	1	2	2	2	2	3	3

**Table A12 Allowable reductions in base thickness for insulated timber framed walls**

Thermal conductivity of insulation within frame (W/m·K)	Thermal conductivity of insulant (W/m·K) 0.020 0.025 0.030 0.035 0.040 0.045 0.050							
	Reduction in base thickness of insulation material (mm) for each 100mm of frame (mm)							
	A	B	C	D	E	F	G	H
1 0.035	39	49	59	69	79	89	99	99
2 0.040	36	45	55	64	73	82	91	91

Note  
The table is derived for walls for which the proportion of timber is 15%, which corresponds to 38mm wide studs at 600mm centres and includes horizontal noggings etc. and the effects of additional timbers at junctions and around openings. For other proportions of timber the U-value can be calculated using the procedure in Appendix B.

**Example 4: Masonry cavity wall with internal insulation**

Determine the thickness of the insulation layer required to achieve a U-value of 0.35 W/m<sup>2</sup>K for the wall construction shown below.

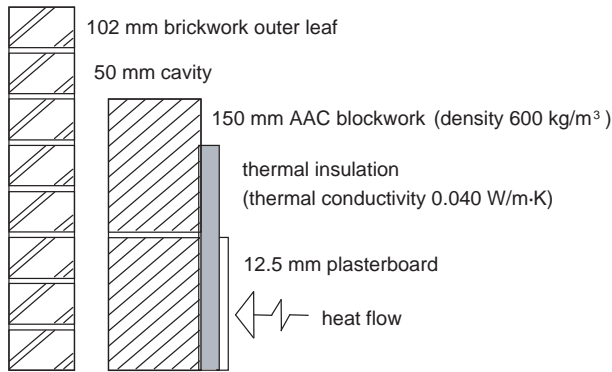

Using Table A9:

From **column F, row 4** of the table, the base thickness of the insulation layer is 107mm.

The base thickness may be reduced by taking account of the other materials as follows:

From Table A10:

- Brickwork outer leaf **column F, row 2** = 5mm
- Cavity **column F, row 1** = 7mm
- Plasterboard **column F, row 6** = 3mm

And from table A11

- Concrete blockwork **column F, row 1** adjusted for 150mm block thickness (1.5 x 17) = 26mm
- Total reduction = 41mm

The minimum thickness of the insulation layer required to achieve a U-value of 0.35 W/m<sup>2</sup>K is therefore:

*Base thickness less total reduction*  
i.e. 107 – 41 = **66mm.**

**Example 5: Masonry cavity wall (tied with vertical-twist stainless-steel ties) filled with insulation with plasterboard on dabs**

Determine the thickness of the insulation layer required to achieve a U-value of 0.37 W/m<sup>2</sup>K for the wall construction shown below. From Table A4 there is a ΔU correction for the wall ties of 0.02 W/m<sup>2</sup>K which applies. To allow for this, the 'look-up' U-value is reduced by 0.02 W/m<sup>2</sup>K to 0.35 W/m<sup>2</sup>K.

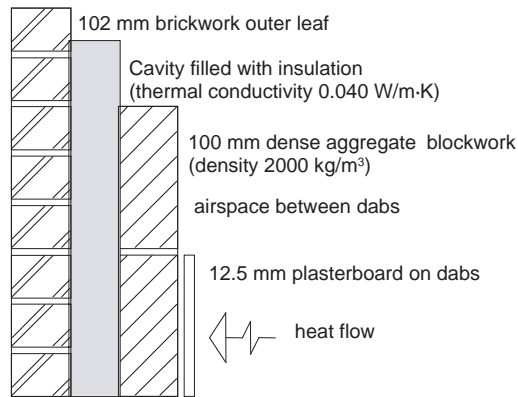

Using Table A9:

From **column F, row 4** of the table, the base thickness of the insulation layer is 107mm.

The base thickness may be reduced by taking account of the other materials as follows:

From Table A10:

- Brickwork outer leaf **column F, row 2** = 5mm
- Plasterboard **column F, row 6** = 3mm
- Airspace behind plasterboard **column F, row 7** = 5mm

And from Table A11:

- Concrete blockwork **column F, row 1** = 3mm
- Total reduction = 16mm

The minimum thickness of the insulation layer required to achieve a U-value of 0.37 W/m<sup>2</sup>K (including ΔU for the wall ties) is therefore:

*Base thickness less total reduction*  
i.e. 107 – 16 = **91mm.**



### Example 6: Masonry wall (tied with vertical-twist stainless-steel ties) with partial cavity-fill

Determine the thickness of the insulation layer required to achieve a U-value of 0.32 W/m<sup>2</sup>K for the wall construction shown below. From Table A4 there is a ΔU correction for the wall ties of 0.02 W/m<sup>2</sup>K which applies. To allow for this, the 'look-up' U-value is reduced by 0.02 W/m<sup>2</sup>K to 0.30 W/m<sup>2</sup>K.

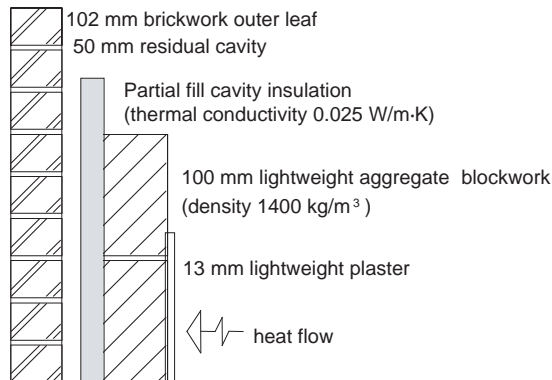

Using Table A9:

From **column C, row 3** of the table, the base thickness of the insulation layer is 79mm.

The base thickness may be reduced by taking account of the other materials as follows:

From Table A10:

- Brickwork outer leaf **column C, row 2** = 3mm
- Cavity **column C, row 1** = 5mm
- Lightweight plaster **column C, row 4** = 2mm

And from Table A11:

- Concrete blockwork **column C, row 5** = 4mm
- Total reduction = 14mm

The minimum thickness of the insulation layer required to achieve a U-value of 0.3 W/m<sup>2</sup>K (including ΔU for the wall ties) is therefore:

*Base thickness less total reduction* i.e.  
79 – 14 = **65mm**.

### Example 7: Timber-framed wall

Determine the thickness of the insulation layer required to achieve a U-value of 0.35 W/m<sup>2</sup>K for the wall construction shown below.

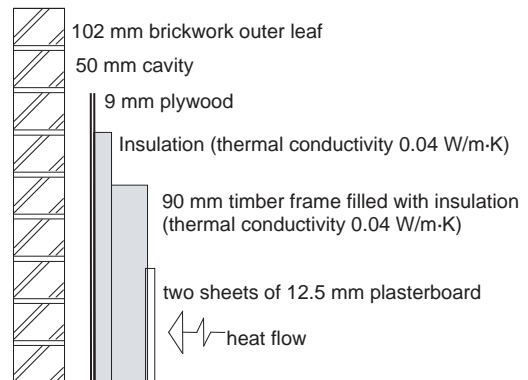

Using Table A9:

From **column F, row 4** of the table, the base thickness of the insulation layer is 107mm.

The base thickness may be reduced by taking account of the other materials as follows:

From Table A10:

- Brickwork outer leaf **column F, row 2** = 5mm
- Cavity **column F, row 1** = 7mm
- Sheathing ply **column F, row 8** = 3mm
- Plasterboard **column F, row 6** = 3mm
- Plasterboard **column F, row 6** = 3mm

And from Table A12:

- Timber frame **column F, row 2**  
adjusted for  
stud thickness  
(73mm x 90/100) = 66mm
- Total reduction = 87mm

The minimum thickness of the insulation layer required to achieve a U-value of 0.35 W/m<sup>2</sup>K is therefore:

*Base thickness less total reduction*  
i.e. 107 - 87 = **20mm**.

## Ground floors

Note: in using the tables for floors it is first necessary to calculate the ratio P/A, where P is the floor perimeter length in metres and A is the floor area in square metres.

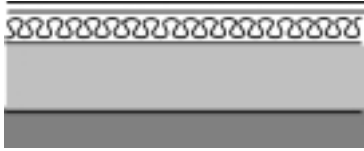
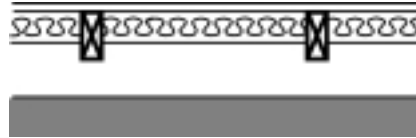

**Table A13 Insulation thickness for solid floors in contact with the ground**

Insulation thickness (mm) for U-value of 0.20 W/m <sup>2</sup> K								
Thermal conductivity of insulant (W/m·K)								
P/A	0.020	0.025	0.030	0.035	0.040	0.045	0.050	
	A	B	C	D	E	F	G	H
1	1.00	81	101	121	142	162	182	202
2	0.90	80	100	120	140	160	180	200
3	0.80	78	98	118	137	157	177	196
4	0.70	77	96	115	134	153	173	192
5	0.60	74	93	112	130	149	167	186
6	0.50	71	89	107	125	143	160	178
7	0.40	67	84	100	117	134	150	167
8	0.30	60	74	89	104	119	134	149
9	0.20	46	57	69	80	92	103	115
U-value of 0.25 W/m <sup>2</sup> K								
10	1.00	61	76	91	107	122	137	152
11	0.90	60	75	90	105	120	135	150
12	0.80	58	73	88	102	117	132	146
13	0.70	57	71	85	99	113	128	142
14	0.60	54	68	82	95	109	122	136
15	0.50	51	64	77	90	103	115	128
16	0.40	47	59	70	82	94	105	117
17	0.30	40	49	59	69	79	89	99
18	0.20	26	32	39	45	52	58	65
U-value of 0.30 W/m <sup>2</sup> K								
19	1.00	48	60	71	83	95	107	119
20	0.90	47	58	70	81	93	105	116
21	0.80	45	56	68	79	90	102	113
22	0.70	43	54	65	76	87	98	108
23	0.60	41	51	62	72	82	92	103
24	0.50	38	47	57	66	76	85	95
25	0.40	33	42	50	59	67	75	84
26	0.30	26	33	39	46	53	59	66
27	0.20	13	16	19	22	25	28	32

Note  
P/A is the ratio of floor perimeter (m) to floor area (m<sup>2</sup>).

**Table A14 Insulation thickness for suspended timber ground floors**

Insulation thickness (mm) for U-value of 0.20 W/m <sup>2</sup> K								
Thermal conductivity of insulant (W/m·K)								
P/A	0.020	0.025	0.030	0.035	0.040	0.045	0.050	
	A	B	C	D	E	F	G	H
1	1.00	127	145	164	182	200	218	236
2	0.90	125	144	162	180	198	216	234
3	0.80	123	142	160	178	195	213	230
4	0.70	121	139	157	175	192	209	226
5	0.60	118	136	153	171	188	204	221
6	0.50	114	131	148	165	181	198	214
7	0.40	109	125	141	157	173	188	204
8	0.30	99	115	129	144	159	173	187
9	0.20	82	95	107	120	132	144	156
U-value of 0.25 W/m <sup>2</sup> K								
10	1.00	93	107	121	135	149	162	176
11	0.90	92	106	119	133	146	160	173
12	0.80	90	104	117	131	144	157	170
13	0.70	88	101	114	127	140	153	166
14	0.60	85	98	111	123	136	148	161
15	0.50	81	93	106	118	130	142	154
16	0.40	75	87	99	110	121	132	143
17	0.30	66	77	87	97	107	117	127
18	0.20	49	57	65	73	81	88	96
U-value of 0.30 W/m <sup>2</sup> K								
19	1.00	71	82	93	104	114	125	135
20	0.90	70	80	91	102	112	122	133
21	0.80	68	78	89	99	109	119	129
22	0.70	66	76	86	96	106	116	126
23	0.60	63	73	82	92	102	111	120
24	0.50	59	68	78	87	96	104	113
25	0.40	53	62	70	79	87	95	103
26	0.30	45	52	59	66	73	80	87
27	0.20	28	33	38	42	47	51	56

Notes  
P/A is the ratio of floor perimeter (m) to floor area (m<sup>2</sup>). The table is derived for suspended timber floors for which the proportion of timber is 12%, which corresponds to 48mm wide timbers at 400mm centres.

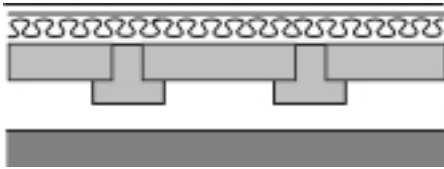

**Table A15 Insulation thickness for suspended concrete beam and block ground floors**

Insulation thickness (mm) for U-value of 0.20 W/m <sup>2</sup> K								
Thermal conductivity of insulant (W/m·K)								
P/A	0.020	0.025	0.030	0.035	0.040	0.045	0.050	
A	B	C	D	E	F	G	H	
1	1.00	82	103	123	144	164	185	205
2	0.90	81	101	122	142	162	183	203
3	0.80	80	100	120	140	160	180	200
4	0.70	79	99	118	138	158	177	197
5	0.60	77	96	116	135	154	173	193
6	0.50	75	93	112	131	150	168	187
7	0.40	71	89	107	125	143	161	178
8	0.30	66	82	99	115	132	148	165
9	0.20	56	69	83	97	111	125	139
U-value of 0.25 W/m <sup>2</sup> K								
10	1.00	62	78	93	109	124	140	155
11	0.90	61	76	92	107	122	138	153
12	0.80	60	75	90	105	120	135	150
13	0.70	59	74	88	103	118	132	147
14	0.60	57	71	86	100	114	128	143
15	0.50	55	68	82	96	110	123	137
16	0.40	51	64	77	90	103	116	128
17	0.30	46	57	69	80	92	103	115
18	0.20	36	45	54	62	71	80	89
U-value of 0.30 W/m <sup>2</sup> K								
19	1.00	49	61	73	85	97	110	122
20	0.90	48	60	72	84	96	108	120
21	0.80	47	59	70	82	94	105	117
22	0.70	45	57	68	80	91	102	114
23	0.60	44	55	66	77	88	98	109
24	0.50	41	52	62	72	83	93	104
25	0.40	38	48	57	67	76	86	95
26	0.30	33	41	49	57	65	73	81
27	0.20	22	28	33	39	44	50	56

Note  
P/A is the ratio of floor perimeter (m) to floor area (m<sup>2</sup>).

### Example 8: Solid floor in contact with the ground

Determine the thickness of the insulation layer required to achieve a U-value of 0.3 W/m<sup>2</sup>K for the ground floor slab shown below.

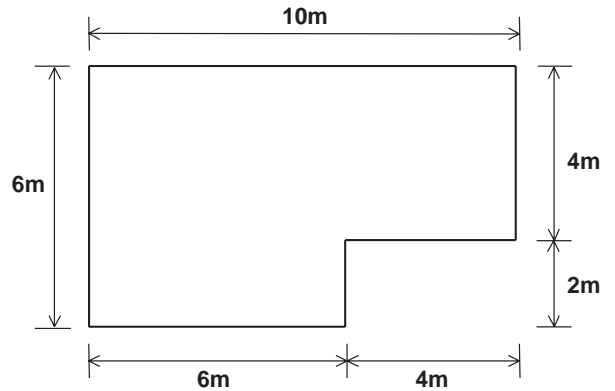

It is proposed to use insulation with a thermal conductivity of 0.025 W/m·K.

The overall perimeter length of the slab is (10 + 4 + 4 + 2 + 6 + 6) = 32m.

The floor area of the slab is (6 x 6) + (4 x 4) = 52 m<sup>2</sup>.

The ratio:

$$\frac{\text{perimeter length}}{\text{floor area}} = \frac{32}{52} = 0.6$$

Using Table A13, **column C, row 23** indicates that **51mm** of insulation is required.

### Example 9: Suspended timber floor

If the floor shown above was of suspended timber construction, the perimeter length and floor area would be the same, yielding the same ratio of:

$$\frac{\text{perimeter length}}{\text{floor area}} = \frac{32}{52} = 0.6$$

To achieve a U-value of 0.30 W/m<sup>2</sup>·K, using insulation with a thermal conductivity of 0.04 W/mK, Table A14 **column F, row 23** indicates that the insulation thickness between the joists should be not less than **102mm**.

## Upper floors

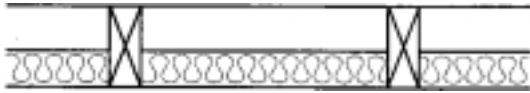

**Table A16 Upper floors of timber construction**

Thermal conductivity of insulant (W/m·K)  
0.020 0.025 0.030 0.035 0.040 0.045 0.050

Design U-value (W/m²K)	Base thickness of insulation between joints to achieve design U-values							
	A	B	C	D	E	F	G	H
1	0.20	167	211	256	298	341	383	426
2	0.25	109	136	163	193	225	253	281
3	0.30	80	100	120	140	160	184	208

Note  
Table A16 is derived for floors with the proportion of timber at 12% which corresponds to 48mm wide timbers at 400mm centres. For other proportions of timber the U-value can be calculated using the procedure in Appendix B.



**Table A17 Upper floors of concrete construction**

Thermal conductivity of insulant (W/m·K)  
0.020 0.025 0.030 0.035 0.040 0.045 0.050

Design U-value (W/m²K)	Base thickness of insulation to achieve design U-values							
	A	B	C	D	E	F	G	H
1	0.20	95	119	142	166	190	214	237
2	0.25	75	94	112	131	150	169	187
3	0.30	62	77	92	108	123	139	154

**Table A18 Upper floors: allowable reductions in base thickness for common components**

Thermal conductivity of insulant (W/m·K)  
0.020 0.025 0.030 0.035 0.040 0.045 0.050

Component	Reduction in base thickness of insulating material (mm)							
	A	B	C	D	E	F	G	H
1 10mm plasterboard		1	2	2	2	3	3	3
2 19mm timber flooring		3	3	4	5	5	6	7
3 50mm screed		2	3	4	4	5	5	6

## Building materials

**Table A19 Thermal conductivity of some common building materials**

	Density (kg/m³)	Conductivity (W/m·K)
<b>Walls</b>		
Brickwork (outer leaf)	1700	0.77
Brickwork (inner leaf)	1700	0.56
Lightweight aggregate concrete block	1400	0.57
Autoclaved aerated concrete block	600	0.18
Concrete (medium density) (inner leaf)	1800	1.13
	2000	1.33
	2200	1.59
Concrete (high density)	2400	1.93
Reinforced concrete (1% steel)	2300	2.3
Reinforced concrete (2% steel)	2400	2.5
Mortar (protected)	1750	0.88
Mortar (exposed)	1750	0.94
Gypsum	600	0.18
	900	0.3
	1200	0.43
Gypsum plasterboard	900	0.25
Sandstone	2600	2.3
Limestone (soft)	1800	1.1
Limestone (hard)	2200	1.7
Fibreboard	400	0.1
Plasterboard	900	0.25
Tiles (ceramic)	2300	1.3
Timber (softwood, plywood, chipboard)	500	0.13
Timber (hardwood)	700	0.18
Wall ties (stainless steel)	7900	17.0
<b>Surface finishes</b>		
External rendering	1300	0.57
Plaster (dense)	1300	0.57
Plaster (lightweight)	600	0.18
<b>Roofs</b>		
Aerated concrete slab	500	0.16
Asphalt	2100	0.7
Felt/bitumen layers	1100	0.23
Screed	1200	0.41
Stone chippings	2000	2.0
Tiles (clay)	2000	1.0
Tiles (concrete)	2100	1.5
Wood wool slab	500	0.1
<b>Floors</b>		
Cast concrete	2000	1.35
Metal tray (steel)	7800	50.0
Screed	1200	0.41
Timber (softwood), plywood, chipboard	500	0.13
Timber (hardwood)	700	0.18
<b>Insulation</b>		
Expanded polystyrene (EPS) board	15	0.04
Mineral wool quilt	12	0.042
Mineral wool batt	25	0.038
Phenolic foam board	30	0.025
Polyurethane board	30	0.025
Note If available, certified test values should be used in preference to those in the table.		

# Appendix B: Calculating U-values

## Introduction

**B1** For building elements which contain repeating thermal bridges, such as timber joists between insulation in a roof or mortar joints around lightweight blockwork in a wall, the effect of thermal bridges should be taken into account when calculating the U-value. Other factors, such as metal wall ties and air gaps around insulation should also be included. The calculation method, known as the Combined Method, is set out in BS EN ISO 6946 and the following examples illustrate the use of the method for typical wall, roof and floor designs.

**B2** In cases where the joists in roof, wall or floor constructions project beyond the surface of the insulation, the depths of the joists should be taken to be the same as the thickness of insulation for the purposes of the U-value calculation (as specified in BS EN ISO 6946).

**B3** Thermal conductivity values for common building materials can be obtained from the CIBSE Guide Section A3 or from EN ISO 12524. For specific insulation products, however, data should be obtained from manufacturers.

**B4** The procedure in this Appendix does not apply to elements containing metal connecting paths, for which the reader is directed to BRE IP 5/98 for metal cladding and to BS EN ISO 10211-1 and -2 for other cases, and it does not deal with ground floors and basements (which are dealt with in Appendix C).

**B5** The examples are offered as indicating ways of meeting the requirements of Part L but designers also have to ensure that their designs comply with all the other parts of Schedule 1 to the Building Regulations.

## The procedure

**B6** The U-value is calculated by applying the following steps:

a) Calculate the upper resistance limit ( $R_{upper}$ ) by combining in parallel the total resistances of all possible heat-flow paths (i.e. sections) through the plane building element.

b) Calculate the lower resistance limit ( $R_{lower}$ ) by combining in parallel the resistances of the heat flow paths of each layer separately and then summing the resistances of all layers of the plane building element.

c) Calculate the U-value of the element from  $U = 1/R_T$ ,

$$\text{where } R_1 = \frac{R_{upper} + R_{lower}}{2}$$

d) Adjust the U-value as appropriate to take account of metal fasteners and air gaps.

## Example 1: Cavity wall with lightweight masonry leaf and insulated dry-lining

In this example there are two bridged layers - insulation bridged by timber and lightweight blockwork bridged by mortar (for a single bridged layer see the next example).

**Diagram B1: Wall construction with two bridged layers**

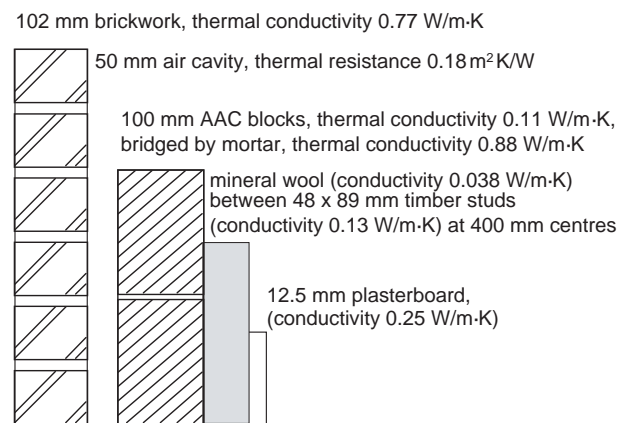

(Total thickness 353.5mm,  $U = 0.32 \text{ W/m}^2\text{K}$ )

Layer	Material	Thickness (mm)	Thermal conductivity (W/m-K)	Thermal resistance (m²K/W)
	external surface	-	-	0.040
1	outer leaf brickwork	102	0.77	0.132
2	air cavity (unvented)	50	-	0.180
3(a)	AAC blocks (93%)	100	0.11	0.909
3(b)	mortar (7%)	(100)	0.88	0.114
4(a)	mineral wool (88%)	89	0.038	2.342
4(b)	timber battens (12%)	(89)	0.13	0.685
5	plasterboard	12.5	0.25	0.050
	internal surface	-	-	0.130

## Upper resistance limit

There are four possible sections (or paths) through which heat can pass. The upper limit of resistance is therefore given by  $R_{upper} = 1/(F_1/R_1 + \dots + F_4/R_4)$  where  $F_m$  is the fractional area of section  $m$  and  $R_m$  is the total thermal resistance of section  $m$ . A conceptual illustration of the upper limit of resistance is shown in Diagram B2.

**Diagram B2: Conceptual illustration of the upper limit of resistance**

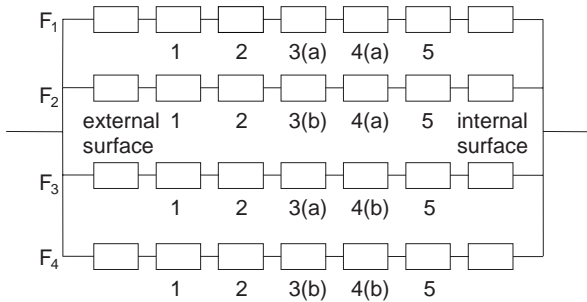

### Resistance through section containing AAC blocks and mineral wool

External surface resistance	= 0.040
Resistance of brickwork	= 0.132
Resistance of air cavity	= 0.180
Resistance of AAC blocks	= 0.909
Resistance of mineral wool	= 2.342
Resistance of plasterboard	= 0.050
Internal surface resistance	= 0.130
Total thermal resistance $R_1$	= <u>3.783 m<sup>2</sup>K/W</u>

Fractional area  $F_1 = 93\% \times 88\% = 0.818$

### Resistance through section containing mortar and mineral wool

External surface resistance	= 0.040
Resistance of brickwork	= 0.132
Resistance of air cavity	= 0.180
Resistance of mortar	= 0.114
Resistance of mineral wool	= 2.342
Resistance of plasterboard	= 0.050
Internal surface resistance	= 0.130
Total thermal resistance $R_2$	= <u>2.988 m<sup>2</sup>K/W</u>

Fractional area  $F_2 = 7\% \times 88\% = 0.062$

### Resistance through section containing AAC blocks and timber

External surface resistance	= 0.040
Resistance of brickwork	= 0.132
Resistance of air cavity	= 0.180
Resistance of AAC blocks	= 0.909
Resistance of timber	= 0.685
Resistance of plasterboard	= 0.050
Internal surface resistance	= 0.130
Total thermal resistance $R_3$	= <u>2.126 m<sup>2</sup>K/W</u>

Fractional area  $F_3 = 93\% \times 12\% = 0.112$

### Resistance through section containing mortar and timber

External surface resistance	= 0.040
Resistance of brickwork	= 0.132
Resistance of air cavity	= 0.180
Resistance of mortar	= 0.114
Resistance of timber	= 0.685
Resistance of plasterboard	= 0.050
Internal surface resistance	= 0.130
Total thermal resistance $R_4$	= <u>1.331 m<sup>2</sup>K/W</u>

Fractional area  $F_4 = 7\% \times 12\% = 0.008$

Combining these resistances we obtain:

$$R_{upper} = \frac{1}{\frac{F_1}{R_1} + \frac{F_2}{R_2} + \frac{F_3}{R_3} + \frac{F_4}{R_4}} = \frac{1}{\frac{0.818}{3.783} + \frac{0.062}{2.988} + \frac{0.112}{2.126} + \frac{0.008}{1.331}}$$

$$= 3.382 \text{ m}^2\text{K/W.}$$

## Lower resistance limit

A conceptual illustration of the lower limit of resistance is shown in the Diagram B3.

**Diagram B3: Conceptual illustration of the lower limit of resistance**

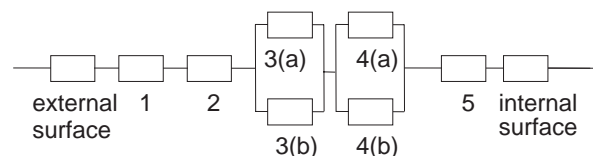

The resistances of the layers are added together to give the lower limit of resistance. The resistance of the bridged layer consisting of AAC blocks and mortar is calculated using:

$$R = \frac{1}{\frac{F_{\text{blocks}}}{R_{\text{blocks}}} + \frac{F_{\text{mortar}}}{R_{\text{mortar}}}}$$

and the resistance of the bridged layer consisting of insulation and timber is calculated using:

$$R = \frac{1}{\frac{F_{\text{insul}}}{R_{\text{insul}}} + \frac{F_{\text{timber}}}{R_{\text{timber}}}}$$

The lower limit of resistance is then obtained by adding together the resistances of the layers:

- External surface resistance = 0.040
- Resistance of brickwork = 0.132
- Resistance of air cavity = 0.180
- Resistance of first bridged layer (blocks and mortar)

$$= \frac{1}{\frac{0.93}{0.909} + \frac{0.707}{0.114}} = 0.611$$

Resistance of second bridged layer (insulation and timber)

$$= \frac{1}{\frac{0.88}{2.342} + \frac{0.12}{0.685}} = 1.815$$

- Resistance of plasterboard = 0.050
- Internal surface resistance = 0.130
- Total ( $R_{\text{lower}}$ ) = 2.958 m<sup>2</sup>K/W

**Total resistance of wall**

The total resistance of the wall is the average of the upper and lower limits of resistance:

$$R_T = \frac{R_{\text{upper}} + R_{\text{lower}}}{2} = \frac{3.382 + 2.958}{2} = 3.170 \text{ m}^2\text{K/W.}$$

**Correction for air gaps**

If there are small air gaps penetrating the insulating layer a correction should be applied to the U-value. The correction for air gaps is  $\Delta U_g$ , where

$$\Delta U_g = \Delta U'' \times (R_l / R_T)^2$$

and where  $R_l$  is the thermal resistance of the layer containing gaps,  $R_T$  is the total resistance

of the element and  $\Delta U''$  is a factor which depends upon the way in which the insulation is fitted. In this example  $R_l$  is 1.815 m<sup>2</sup>K/W,  $R_T$  is 3.170 m<sup>2</sup>K/W and  $\Delta U''$  is 0.01 (ie correction level 1<sup>1</sup>). The value of  $\Delta U_g$  is then  $\Delta U_g = 0.01 \times (1.815/3.170)^2 = 0.003 \text{ W/m}^2\text{K.}$

**U-value of the wall**

The effect of air gaps or mechanical fixings<sup>2</sup> should be included in the U-value unless they lead to an adjustment in the U-value of less than 3%.

- $U = 1/R_T + \Delta U_g$  (if  $\Delta U_g$  is not less than 3% of  $1/R_T$ )
- $U = 1/R_T$  (if  $\Delta U_g$  is less than 3% of  $1/R_T$ )

In this case  $\Delta U_g = 0.003 \text{ W/m}^2\text{K}$  and  $1/R_T = 0.315 \text{ W/m}^2\text{K}$ , i.e.  $\Delta U_g$  is less than 3% of  $(1/R_T)$ .

Therefore  $U = 1/R_T = 1/3.170 = 0.32 \text{ W/m}^2\text{K}$  (expressed to two decimal places).

<sup>1</sup> Applies for "Insulation installed in such a way that no air circulation is possible on the warm side of the insulation; air gaps may penetrate the insulation layer"  
<sup>2</sup> In this case the wall ties within the cavity do not penetrate any insulating layer and their effects need not be taken into account

## Example 2: Timber framed wall

In this example there is a single bridged layer in the wall, involving insulation bridged by timber studs. The construction consists of outer leaf brickwork, a clear ventilated cavity, 10mm plywood, 38 x 140mm timber framing with 140mm of mineral wool quilt insulation between the timber studs and 2 sheets of plasterboard, each 12.5mm thick, incorporating a vapour check.

The timber fraction in this particular example is 15%. This corresponds to 38mm wide studs at 600mm centres and includes horizontal noggings etc. and the effects of additional timbers at junctions and around openings.

### Diagram B4: Timber framed wall construction

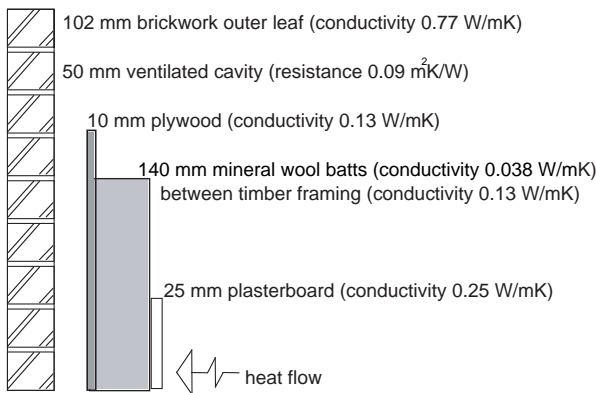

(Total thickness 327mm,  $U = 0.30 \text{ W/m}^2\text{K}$ )

The thicknesses of each layer, together with the thermal conductivities of the materials in each layer, are shown below. The internal and external surface resistances are those appropriate for wall constructions. Layer 4 is thermally bridged and two thermal conductivities are given for this layer, one for the main part and one for the bridging part of the layer. For each homogeneous layer and for each section through a bridged layer, the thermal resistance is calculated by dividing the thickness (in metres) by the thermal conductivity.

Layer	Material	Thickness (mm)	Thermal conductivity (W/m·K)	Thermal resistance (m²K/W)
	external surface	-	-	0.040
1	outer leaf brick	102	0.77	0.132
2	ventilated air cavity	50	-	0.090
3	plywood	10	0.13	0.077
4(a)	mineral wool quilt between timber framing (85%)	140	0.038	3.684
4(b)	timber framing (15%)	(140)	0.13	1.077
5	plasterboard	25	0.25	0.100
	internal surface	-	-	0.130

Both the upper and the lower limits of thermal resistance are calculated by combining the alternative resistances of the bridged layer in proportion to their respective areas, as illustrated below. The method of combining differs in the two cases.

### Upper resistance limit

When calculating the upper limit of thermal resistance, the building element is considered to consist of two thermal paths (or sections). The upper limit of resistance is calculated from:

$$R_{\text{upper}} = \frac{1}{\frac{F_1}{R_1} + \frac{F_2}{R_2}}$$

where  $F_1$  and  $F_2$  are the fractional areas of the two sections (paths) and  $R_1$  and  $R_2$  are the total resistances of the two sections. The method of calculating the upper resistance limit is illustrated conceptually in Diagram B5.

### Diagram B5: Conceptual illustration of how to calculate the upper limit of thermal resistance

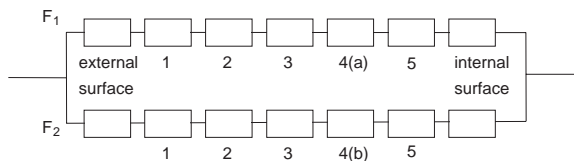



**Resistance through the section containing insulation**

External surface resistance	= 0.040
Resistance of bricks	= 0.132
Resistance of air cavity	= 0.090
Resistance of plywood	= 0.077
Resistance of mineral wool (85%)	= 3.684
Resistance of plasterboard	= 0.100
Internal surface resistance	= 0.130
Total ( $R_1$ )	= <u>4.253</u>

Fractional area  $F_1 = 0.85$  (85%)

The resistance through this section is therefore 4.253 m<sup>2</sup>K/W.

**Resistance through section containing timber stud**

External surface resistance	= 0.040
Resistance of bricks	= 0.132
Resistance of air cavity	= 0.090
Resistance of plywood	= 0.077
Resistance of timber studs (15%)	= 1.077
Resistance of plasterboard	= 0.100
Internal surface resistance	= 0.130
Total ( $R_2$ )	= <u>1.646</u>

Fractional area  $F_2 = 0.15$  (15%)

The resistance through this section is therefore 1.646 m<sup>2</sup>K/W.

The upper limit of resistance is then:

$$R_{upper} = \frac{1}{\frac{F_1}{R_1} + \frac{F_2}{R_2}} = \frac{1}{\frac{0.85}{4.253} + \frac{0.15}{1.646}} = 3.437 \text{ m}^2\text{K/W.}$$

**Lower resistance limit**

When calculating the lower limit of thermal resistance, the resistance of a bridged layer is determined by combining in parallel the resistances of the unbridged part and the bridged part of the layer. The resistances of all the layers in the element are then added together to give the lower limit of resistance.

The resistance of the bridged layer is calculated using:

$$R = \frac{1}{\frac{F_{insul}}{R_{insul}} + \frac{F_{timber}}{R_{timber}}}$$

The method of calculating the lower limit of resistance is illustrated conceptually in Diagram B6.

**Diagram B6: Conceptual illustration of how to calculate the lower limit of thermal resistance**

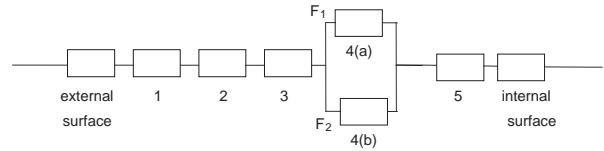

The lower limit of resistance is then obtained by adding up the resistances of all the layers:

External surface resistance	= 0.040
Resistance of bricks	= 0.132
Resistance of air cavity	= 0.090
Resistance of plywood	= 0.077

$$\text{Resistance of bridged layer} = \frac{1}{\frac{0.85}{3.684} + \frac{0.15}{1.077}} = 2.703$$

Resistance of plasterboard	= 0.100
Internal surface resistance	= 0.130
Total ( $R_{lower}$ )	= <u>3.272</u>

The lower limit of resistance is then 3.272 m<sup>2</sup>K/W.

**Total resistance of wall (not allowing for air gaps around the insulation)**

The total resistance of the wall is the average of the upper and lower resistance limits:

$$R_T = \frac{R_{upper} + R_{lower}}{2} = \frac{3.437 + 3.272}{2} = 3.354 \text{ m}^2\text{K/W.}$$

**Correction for air gaps**

If there are small air gaps penetrating the insulating layer a correction should be applied to the U-value to account for this. The correction for air gaps is  $\Delta U_g$ , where

$$\Delta U_g = \Delta U'' \times (R_l/R_T)^2$$

and where  $R_l$  is the thermal resistance of the layer containing gaps,  $R_T$  is the total resistance

## L1 CALCULATING U-VALUES

---

of the element and  $\Delta U''$  is a factor which depends upon the way in which the insulation is fitted. In this example  $R_i$  is  $2.703 \text{ m}^2\text{K/W}$ ,  $R_T$  is  $3.354 \text{ m}^2\text{K/W}$  and  $\Delta U''$  is  $0.01$  (ie correction level 1). The value of  $\Delta U_g$  is then  $\Delta U_g = 0.01 \times (2.703/3.354)^2 = 0.006 \text{ W/m}^2\text{K}$ .

### U-value of the wall

The effect of air gaps or mechanical fixings should be included in the U-value unless they lead to an adjustment in the U-value of less than 3%.

$$U = 1/R_T + \Delta U_g \quad (\text{if } \Delta U_g \text{ is not less than } 3\% \text{ of } 1/R_T)$$

$$U = 1/R_T \quad (\text{if } \Delta U_g \text{ is less than } 3\% \text{ of } 1/R_T)$$

In this case  $\Delta U_g = 0.006 \text{ W/m}^2\text{K}$  and  $1/R_T = 0.298 \text{ W/m}^2\text{K}$ . Since  $\Delta U_g$  is less than 3% of  $(1/R_T)$ ,

$$U = 1/R_T = 1 / 3.354 = 0.30 \text{ W/m}^2\text{K}.$$

## Appendix C: U-values of ground floors

**C1** The guidance in this Approved Document states that a ground floor should not have a U-value exceeding  $0.25 \text{ W/m}^2\text{K}$  if the Elemental Method of compliance is to be used. This can normally be achieved without the need for insulation if the perimeter to area ratio is less than  $0.12 \text{ m/m}^2$  for solid ground floors or less than  $0.09 \text{ m/m}^2$  for suspended floors. For most buildings, however, some ground floor insulation will be necessary to achieve this U-value or better performance. For exposed floors and for floors over unheated spaces the reader is referred to BS EN ISO 6946 or the CIBSE Guide Section A3.

**C2** This Appendix provides a simple method for determining U-values which will suffice for most common constructions and ground conditions in the UK. More rigorous procedures are given in BS EN ISO 13370 and in CIBSE Guide Section A3 (1999 edition).

**C3** For ground floors the U-value depends upon the type of soil beneath the building. Where the soil type is unknown, clay soil should be assumed as this is the most typical soil type in the UK. The tables which follow are based on this soil type. Where the soil is not clay or silt, the U-value should be calculated using the procedure in BS EN ISO 13370.

**C4** Floor dimensions should be measured between finished internal faces of the external elements of the building including any projecting bays. In the case of semi-detached or terraced premises, blocks of flats and similar, the floor dimensions can either be taken as those of the premises themselves, or of the whole building. When considering extensions to existing buildings the floor dimensions may be taken as those of the complete building including the extension.

**C5** Floor designs should prevent excessive thermal bridging at the floor edge so that the risk of condensation and mould are reasonably controlled. See BRE Report BR 262 *Thermal insulation: avoiding risks*.

**C6** Unheated spaces outside the insulated fabric, such as attached garages or porches, should be excluded when determining the perimeter and area but the length of the wall between the heated building and the unheated space should be included when determining the perimeter.

**C7** Data on U-values and insulation thicknesses for basements are given in the BCA/NHBC Approved Document "Basements for dwellings", ISBN 0-7210-1508-5.

### Example of how to obtain U-values from the tables

The following example illustrates the use of the tables by interpolating between appropriate rows or columns.

A proposed building has a perimeter of  $38.4 \text{ m}$  and a ground floor area of  $74.25 \text{ m}^2$ . The floor construction consists of a  $150 \text{ mm}$  concrete slab,  $95 \text{ mm}$  of rigid insulation (thermal conductivity  $0.04 \text{ W/m}\cdot\text{K}$ ) and a  $65 \text{ mm}$  screed. Only the insulation layer is included in the calculation of the thermal resistance.

Diagram C1

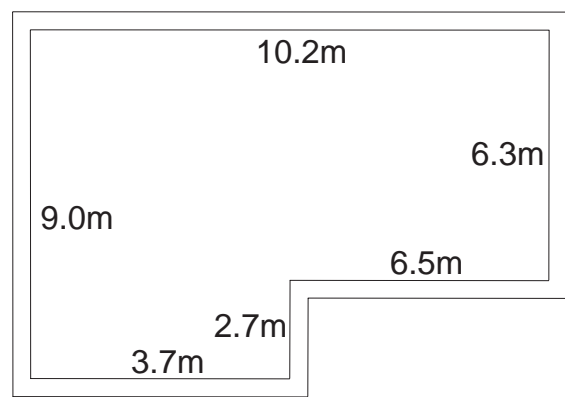

The perimeter to area ratio is equal to  $(38.4/74.25 = 0.517) \text{ m/m}^2$ . Table C1 provides values for perimeter/area ratios of 0.50 and 0.55 but not for any values between 0.50 and 0.55. In this case, the U-value corresponding to a perimeter to area ratio of 0.50 should be used since 0.517 is closer to 0.50 than to 0.55.

The thermal resistance of the insulation is obtained by dividing the thickness (in metres) by the conductivity. The resistance is then  $0.095/0.04 = 2.375 \text{ m}^2\text{K/W}$ .

The relevant part of table C1 is shown below:

Thermal resistance of all-over insulation ( $\text{m}^2\text{K/W}$ )		
perimeter/area	2.0	2.5
0.50	0.28	0.24

# L1 U-VALUES OF GROUND FLOORS

The U-value corresponding to a thermal resistance of 2.375 m<sup>2</sup>K/W is obtained by linear interpolation as below:

$$U = 0.28 \times \frac{2.5 - 2.375}{2.5 - 2.0} + 0.24 \times \frac{2.375 - 2.0}{2.5 - 2.0}$$

$$= 0.28 \times 0.25 + 0.24 \times 0.75$$

$$= 0.25 \text{ W/m}^2\text{K}$$

The U-value of this ground floor is therefore **0.25 W/m<sup>2</sup>K**.

## Note

In the example for Table C1 the appropriate row was chosen and interpolation was carried out between the appropriate columns. For all of the other tables, however, the appropriate column in the table should be selected and interpolation should be carried out between the appropriate rows.

## Solid ground floors

Listed in Table C1 are U-values for solid ground floors. U-values are given in the following table for various perimeter-to-area ratios for a range of insulation levels. Where the floor is uninsulated the column corresponding to a thermal resistance of 0 should be used.

**Table C1 U-values (W/m<sup>2</sup>K) for solid ground floors**

perimeter/ area (m/m <sup>2</sup> )	Thermal resistance of all-over insulation (m <sup>2</sup> K/W)					
	0	0.5	1	1.5	2	2.5
0.05	0.13	0.11	0.10	0.09	0.08	0.08
0.10	0.22	0.18	0.16	0.14	0.13	0.12
0.15	0.30	0.24	0.21	0.18	0.17	0.15
0.20	0.37	0.29	0.25	0.22	0.19	0.18
0.25	0.44	0.34	0.28	0.24	0.22	0.19
0.30	0.49	0.38	0.31	0.27	0.23	0.21
0.35	0.55	0.41	0.34	0.29	0.25	0.22
0.40	0.60	0.44	0.36	0.30	0.26	0.23
0.45	0.65	0.47	0.38	0.32	0.27	0.23
0.50	0.70	0.50	0.40	0.33	0.28	0.24
0.55	0.74	0.52	0.41	0.34	0.28	0.25
0.60	0.78	0.55	0.43	0.35	0.29	0.25
0.65	0.82	0.57	0.44	0.35	0.30	0.26
0.70	0.86	0.59	0.45	0.36	0.30	0.26
0.75	0.89	0.61	0.46	0.37	0.31	0.27
0.80	0.93	0.62	0.47	0.37	0.32	0.27
0.85	0.96	0.64	0.47	0.38	0.32	0.28
0.90	0.99	0.65	0.48	0.39	0.32	0.28
0.95	1.02	0.66	0.49	0.39	0.33	0.28
1.00	1.05	0.68	0.50	0.40	0.33	0.28

## Ground floors with edge insulation

Where horizontal or vertical edge insulation is used instead of all-over floor insulation, (P/A) x Ψ is added to the U-value to account for the effects of edge insulation, where P/A is the perimeter (m) to area (m<sup>2</sup>) ratio and Ψ is the edge insulation factor obtained from one of the following two tables. Since the term (P/A) x Ψ is negative it reduces the U-value of the ground floor. The tables apply only to floors without overall insulation.

**Table C2 Edge insulation factor Ψ (W/m-K) for horizontal edge insulation**

insulation width (m)	thermal resistance of insulation (m <sup>2</sup> K/W)			
	0.5	1.0	1.5	2.0
0.5	-0.13	-0.18	-0.21	-0.22
1.0	-0.20	-0.27	-0.32	-0.34
1.5	-0.23	-0.33	-0.39	-0.42

**Table C3 Edge insulation factor Ψ (W/m-K) for vertical edge insulation**

insulation depth (m)	thermal resistance of insulation (m <sup>2</sup> K/W)			
	0.5	1.0	1.5	2.0
0.25	-0.13	-0.18	-0.21	-0.22
0.50	-0.20	-0.27	-0.32	-0.34
0.75	-0.23	-0.33	-0.39	-0.42
1.00	-0.26	-0.37	-0.43	-0.48

For floors with both all-over insulation and edge insulation the calculation method in BS EN ISO 13370 can be used.

## Uninsulated suspended ground floors

The following table gives U-values of uninsulated suspended floors for various perimeter to area ratios and for two levels of ventilation (expressed in m<sup>2</sup>/m) below the floor deck. The data apply for the floor deck at a height not more than 0.5 m above the external ground level where the wall surrounding the underfloor space is uninsulated.

**Table C4 U-values (W/m<sup>2</sup>K) of uninsulated suspended floors**

perimeter to area ratio (m/m <sup>2</sup> )	Ventilation opening area per unit perimeter of underfloor space	
	0.0015 m <sup>2</sup> /m	0.0030 m <sup>2</sup> /m
0.05	0.15	0.15
0.10	0.25	0.26
0.15	0.33	0.35
0.20	0.40	0.42
0.25	0.46	0.48
0.30	0.51	0.53
0.35	0.55	0.58
0.40	0.59	0.62
0.45	0.63	0.66
0.50	0.66	0.70
0.55	0.69	0.73
0.60	0.72	0.76
0.65	0.75	0.79
0.70	0.77	0.81
0.75	0.80	0.84
0.80	0.82	0.86
0.85	0.84	0.88
0.90	0.86	0.90
0.95	0.88	0.92
1.00	0.89	0.93

## Insulated suspended floors

The U-value of an insulated suspended floor should be calculated using

$$U = 1/[(1/U_0) - 0.2 + R_f]$$

where  $U_0$  is the U-value of an uninsulated suspended floor obtained using Table C4 or another approved method.  $R_f$ , the thermal resistance of the floor deck, is determined from  $U_f$ , the U-value of the floor deck, where

$$R_f = \frac{1}{U_f} - 0.17 - 0.17$$

and where  $U_f$  takes account of any thermal bridging in the floor deck and is calculated as recommended in BS EN ISO 6946 or by numerical modelling. The two values "0.17" are the two surface resistances.

## Appendix D: Determining U-values for glazing

**D1** Within the Elemental Method of compliance it is permissible to have windows, doors or rooflights with U-values that exceed the standard U-values provided that the average U-value of all of the windows (including rooflights) and doors taken together does not exceed the standard U-value in Table 1 in Section 1. The following examples illustrate how this can be done.

### Example 1

**D2** A semi-detached house is to have a total window area of 16.9m<sup>2</sup>, a rooflight of area 0.9m<sup>2</sup> and a total door area of 3.8m<sup>2</sup>. The windows have wood frames. It is proposed to use solid wooden doors with a U-value of 3.0 W/m<sup>2</sup>K. In order to use the Elemental Method, the additional heat loss due to the use of solid timber doors must be compensated by lower U-values the windows so that the average U-value of all openings does not exceed the appropriate standard U-value, which in this case is 2.0 W/m<sup>2</sup>K.

**D3** Using windows with a U-value of 1.7 W/m<sup>2</sup>K is sufficient to satisfy this requirement as shown in the following table and the subsequent calculation.

Element	Area (m <sup>2</sup> )	U-value (W/m <sup>2</sup> K)	Rate of heat loss per degree (W/K)
Windows	16.9	1.7	28.73
Doors	3.8	3.0	11.4
Rooflights	0.9	1.9	1.71
<b>Total</b>	21.6		41.84

**D4** This gives an average U-value of 41.84/21.6, or 1.94 W/m<sup>2</sup>K, which is less than 2.0 W/m<sup>2</sup>K. The windows, doors and rooflights therefore satisfy the requirements of the Elemental Method.

### Example 2

**D5** If, for the same dwelling as example 1, windows with a U-value of 2.1 W/m<sup>2</sup>K are proposed, the requirement can be satisfied by using insulated doors with a U-value of 1.0 W/m<sup>2</sup>K, as shown below.

Element	Area (m <sup>2</sup> )	U-value (W/m <sup>2</sup> K)	Rate of heat loss per degree (W/K)
Windows	16.9	2.1	35.49
Doors	3.8	1.0	3.8
Rooflights	0.9	2.3	2.07
<b>Total</b>	21.6		41.36

**D6** This gives an average U-value of 41.36/21.6, or 1.91 W/m<sup>2</sup>K, which is less than the standard U-value of 2.0 W/m<sup>2</sup>K when wood-framed windows are being used. Taken together, the windows, doors and rooflights therefore satisfy the requirements of the Elemental Method.

# Appendix E: Target U-value examples

**E1** For a dwelling with a heating system based on a gas or oil boiler, the Target U-value is given by

$$U_T = [0.35 - 0.19(A_R/A_T) - 0.10(A_{GF}/A_T) + 0.413(A_F/A_T)]$$

where  $U_T$  is the Target U-value prior to any adjustment for heating system performance or solar gain,  $A_R$  is the exposed roof area,  $A_{GF}$  is the ground floor area,  $A_F$  is the total floor area (all storeys) and  $A_T$  is the total area of exposed elements of the dwelling (including the ground floor).

**E2** A dwelling can comply by the Target U-value method if the Target U-value is not less than the average U-value, where the average U-value is defined as the area-weighted average U-value of all exposed elements of the dwelling. Exposed elements include walls, roofs, floors, windows and doors, including elements adjacent to unheated spaces.

## Example 1 – A semi-detached dwelling

The dwelling in Diagram E1 has details as given in the following table. It is proposed to adopt the Target U-value method with the U-value of the walls a little higher (ie. poorer) than would be required in the Elemental method. The walls are to have a U-value of 0.40 W/m<sup>2</sup>K. The area of windows and doors is equal to 25% of the total internal floor area and the efficiency of the gas boiler is 85%. The total area of North-facing glazed openings is 6.82m<sup>2</sup> and the total area of South-facing glazed openings is 8.88m<sup>2</sup>.

Element	Area (m <sup>2</sup> )	U-value (W/m <sup>2</sup> K)	Rate of heat loss per degree (W/K)
wall	80.3	0.40	32.12
roof	44.4	0.20	8.88
ground floor	44.4	0.25	11.10
windows	18.4	2.2	40.48
doors	3.8	2.2	8.36
<b>Total</b>	<b>191.3</b>	-	<b>100.94</b>

**Diagram E1: Layout of dwelling for Example 1**

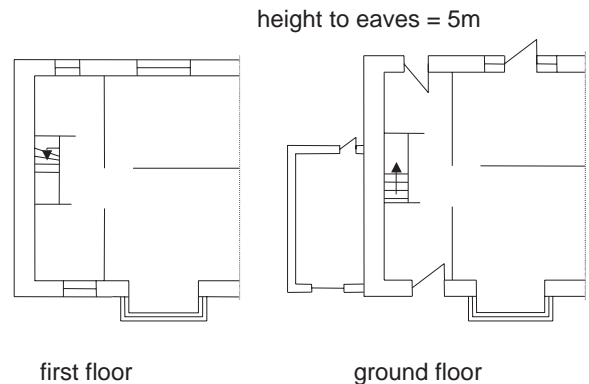

The Target U-value is

$$U_T = [0.35 - 0.19(44.4/191.3) - 0.10(44.4/191.3) + 0.413(88.8/191.3)] = 0.474$$

which is multiplied by  $f_e$ , the ratio of proposed boiler SEDBUK divided by reference boiler SEDBUK (which is 78% for heating by mains gas), giving a Target U-value of

$$U_T \times f_e = 0.474 \times (85\%/78\%) = 0.517$$

Since the area of glazed openings on the South elevations exceeds that on the North, the benefit of solar heat gains can be taken into account to ease the target U-value by adding  $\Delta S$  to the target U-value, where:-

$$\Delta S = 0.04 \times [(A_S - A_N)/A_{TG}]$$

and  $A_S$  = Area of glazed openings facing south;  
 $A_N$  = Area of glazed openings facing north;

$A_{TG}$  = Total area of all glazed openings in the building;

So  $0.04 \times [(8.88 - 6.82)/18.4]$ , or 0.004, is added to the Target U-value, giving a Target U-value of 0.521 W/mK.

The average U-value for the dwelling is given by:

$$U_{avg} = \frac{\text{Total rate of heat loss per degree}}{\text{Total external surface area}}$$

These values are calculated in the above table, and in this case the average U-value is:

$$U_{avg} = \frac{100.94}{191.3} = 0.528 \text{ W/m}^2\text{K.}$$

Since the average U-value is greater than the target U-value the proposed design does not meet the requirements and modifications must be made to the design. The Target U-value method may still be used, however, if the average U-value is reduced or if the Target U-value increased (or both).

# L1 TARGET U-VALUE EXAMPLES

Some ways of modifying the proposed design in order to comply with the Target U-value Method are described below:

a) *Specifying a higher performance heating system*

If the boiler efficiency is 88% the value of  $f_e$ , the ratio of proposed efficiency to base efficiency, will lead to an increase in the Target U-value. This is sufficient to raise the Target U-value above the average U-value giving a final Target U-value of

$$U_T = [0.474 \times (88\%/78\%)] + 0.04 \times [(8.88 - 6.82)/18.4] = 0.539 \text{ W/m}^2\text{K}$$

Since the final Target U-value, 0.539 W/m<sup>2</sup>K, is greater than the average U-value, 0.528 W/m<sup>2</sup>K, compliance with the Target U-value Method is achieved.

b) *Reducing the U-value of the roof and the ground floor*

If the U-value of the roof is reduced from the standard elemental U-value of 0.20 W/m<sup>2</sup>K to 0.15 W/m<sup>2</sup>K the average U-value will be reduced by  $[44.4 \times (0.20 - 0.15)/191.3]$ , or by 0.011 W/m<sup>2</sup>K. This measure is sufficient to reduce the average U-value to less than the Target U-value and satisfy the Target U-value requirement.

$$\text{Average U-value} = 0.528 - 0.011 = 0.517 \text{ W/m}^2\text{K}$$

Since the final average U-value, 0.517 W/m<sup>2</sup>K, is less than the final Target U-value, 0.521 W/m<sup>2</sup>K, compliance with the Target U-value Method is achieved.

c) *Reducing the total area of the windows and doors*

If the total area of windows and doors is reduced from 25% of the floor area to 19% of the floor area the average U-value will be reduced by  $(6\% \text{ of } 88.8) \times (2.2 - 0.40)/191.3$ , or 0.050 W/m<sup>2</sup>K, which is sufficient to reduce the average U-value to below the Target U-value.

$$\text{Average U-value} = 0.528 - 0.050 = 0.478 \text{ W/m}^2\text{K}$$

Since the final average U-value, 0.478 W/m<sup>2</sup>K, is less than the final Target U-value, 0.521 W/m<sup>2</sup>K, compliance with the Target U-value Method is achieved.

d) *Using insulated doors and reducing the area of the windows*

If doors with a U-value of 1.9 W/m<sup>2</sup>K are used instead of 2.2 W/m<sup>2</sup>K the average U-value will fall by  $(2.2 - 1.9) \times 3.8/191.3$ , or 0.006 W/m<sup>2</sup>K. This is not sufficient on its own to reduce the average U-value to below the Target U-value. If, however, the total window area is reduced by 20% then the average U-value will fall by an additional amount equal to  $(20\% \text{ of } 18.4) \times (2.2 - 0.40)/191.3 = 0.035 \text{ W/m}^2\text{K}$ . The dwelling now satisfies the Target U-value Method.

$$\text{Average U-value} = 0.528 - 0.006 - 0.035 = 0.487 \text{ W/m}^2\text{K}$$

Since the final average U-value, 0.487 W/m<sup>2</sup>K, is less than the final Target U-value, 0.521 W/m<sup>2</sup>K, compliance with the Target U-value Method is achieved.

e) *Specifying windows with lower U-value*

Using windows with a U-value of 1.7 W/m<sup>2</sup>K instead of 2.2 W/m<sup>2</sup>K will reduce the average U-value by  $[(2.2 - 1.7) \times 18.4 / 191.3]$ , or 0.048 W/m<sup>2</sup>K. This is sufficient to reduce the average U-value to below the Target U-value. Reducing the window U-value to 1.71 W/m<sup>2</sup>K is therefore sufficient to achieve compliance.

$$\text{Average U-value} = 0.528 - 0.048 = 0.480 \text{ W/m}^2\text{K}$$

Since the final average U-value, 0.480 W/m<sup>2</sup>K, is less than the final Target U-value, 0.521 W/m<sup>2</sup>K, compliance with the Target U-value Method is achieved.

## Example 2 – A detached dwelling

The example in Diagram E2 has details as given in the following table. It is proposed to adopt the Target U-value approach with the walls having a U-value of 0.40 W/m<sup>2</sup>K. To compensate for this the floor U-value is reduced to 0.15 W/m<sup>2</sup>K, the roof U-value is reduced to 0.16 W/m<sup>2</sup>K and the window U-value is reduced to 1.7 W/m<sup>2</sup>K. The SEDBUK efficiency of the oil boiler is equal to the reference SEDBUK efficiency, given in Table 2 of Section 1, which in this case is 84%.

Exposed element	Exposed surface area	U-value	Rate of heat loss per degree
Wall	123.0	0.40	49.2
Roof	52.0	0.16	8.32
Ground floor	52.0	0.15	7.80
Windows & glazed doors*	24.1	1.7	40.97
Solid doors	1.9	3.0	5.7
<b>Totals</b>	<b>253.0</b>		<b>112.0</b>

\*this includes 7.0m<sup>2</sup> of North facing glazing and 8.9 m<sup>2</sup> of South facing glazing



**Diagram E2: Layout of dwelling for Example 2**

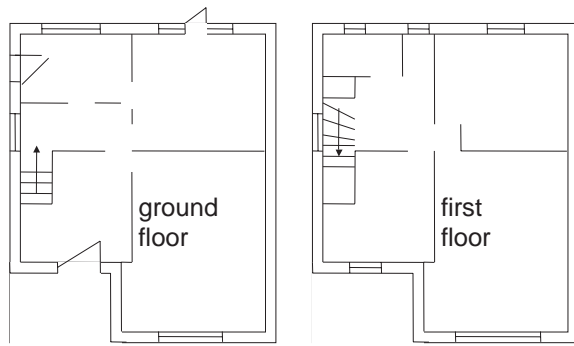

The Target U-value is then

$$\begin{aligned}
 U_T &= [0.35 - 0.19(A_R/A_T) - 0.10(A_{GF}/A_T) + 0.413(A_F/A_T)] \\
 &= [0.35 - 0.19(52/253) - 0.10(52/253) + 0.413(104/253)] = 0.460 \text{ W/m}^2\text{K}.
 \end{aligned}$$

Since the heating system efficiency is equal to the base SEDBUK efficiency, no adjustment is made and  $f_e$  is equal to 1.

The adjustment to the Target U-value for solar gains is

$$0.04 \times [(8.9 - 7.0)/24.1] = 0.003 \text{ W/m}^2\text{K}$$

This gives a final Target U-value of  $0.460 \text{ W/m}^2\text{K} + 0.003 \text{ W/m}^2\text{K}$ , or  $0.463 \text{ W/m}^2\text{K}$ .

The average U-value for the dwelling is given by the following ratio:

$$U_{\text{avg}} = \frac{\text{Total rate of heat loss per degree}}{\text{Total external surface area}}$$

For this example, therefore, the average U-value is

$$U_{\text{avg}} = \frac{112.0}{253.0} = 0.443 \text{ W/m}^2\text{K}$$

Since the average U-value is less than the Target U-value, the proposed design meets the guidance in this Approved Document.

# Appendix F: SAP Ratings and Carbon Indexes

These examples use fabric insulation specifications that would meet the standards given in the Elemental Method.

## Example 1 – Two bedroom mid-terrace house

Diagram F1: Plans of two bedroom mid-terraced house

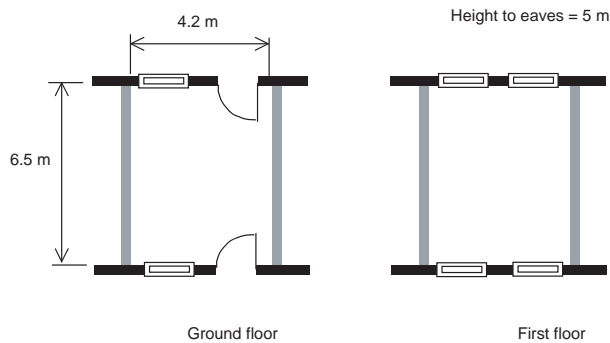

Table F1 Data for the two bedroom mid-terrace house with conventional gas boiler

Element	Description	Area	U-value
Wall	Brick/cavity/dense block with cavity insulation	26.4	0.35
Roof	Pitched roof, insulation between and above joists	27.3	0.16
Ground floor	Suspended timber, insulation between joists	27.3	0.25
Windows and doors	Double glazed low-E, wooden frame	13.6	2.0
Heating	Central heating with conventional gas boiler (efficiency 78%)		
<b>SAP rating = 100</b>			
<b>CI = 8.0</b>			

## Example 2 – Three bedroom semi-detached house

Diagram F2: Plans of three bedroom semi-detached house

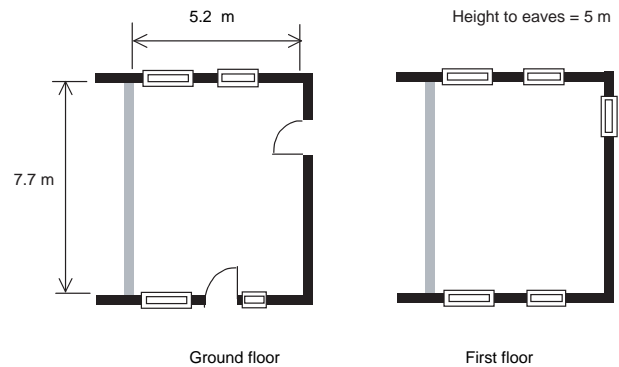

Table F2 Data for the three bedroom semi-detached house with gas boiler

Element	Description	Area	U-value
Wall	Brick/cavity/dense block with cavity insulation	72.5	0.35
Roof	Pitched roof, insulation between and above joists	40.0	0.16
Ground floor	Solid concrete, insulated	40.0	0.25
Windows and doors	Double glazed low-E, PVC-U frame	20.0	2.0
Heating	Central heating with condensing gas boiler (efficiency 88%)		
		<b>Natural gas</b>	<b>LPG</b>
		<b>SAP rating =</b>	<b>101</b>
		<b>63</b>	<b>7.1</b>
		<b>CI =</b>	<b>8.0</b>

## Example 3 – Four bedroom mid-terraced mid-floor flat

Diagram F3: Plan of four bedroom flat

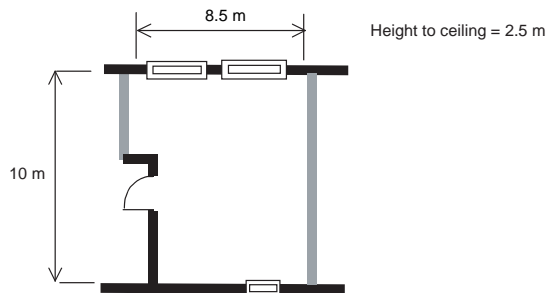

Table F3 Data for four bedroom flat

Element	Description	Area	U-value
Wall	Brick/cavity/dense block with cavity insulation	25.0	0.35
Roof	No heat loss	-	-
Ground floor	No heat loss	-	-
Windows and doors	Double glazed low-E, PVC-U frame	20.0	2.0
Heating	Central heating with gas boiler (efficiency 78%)		
<b>SAP rating = 107</b>			
<b>CI = 8.5</b>			

## Example 4 – Four bedroom detached house

Diagram F4: Plans of four bedroom detached house with condensing gas boiler

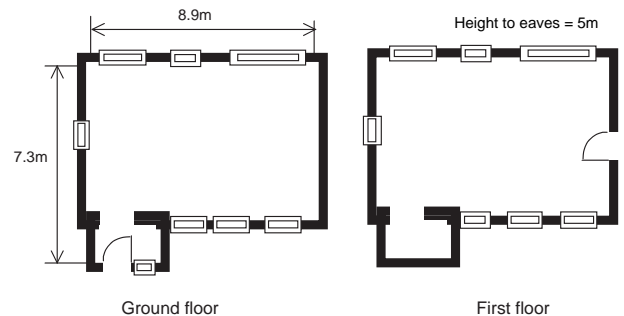
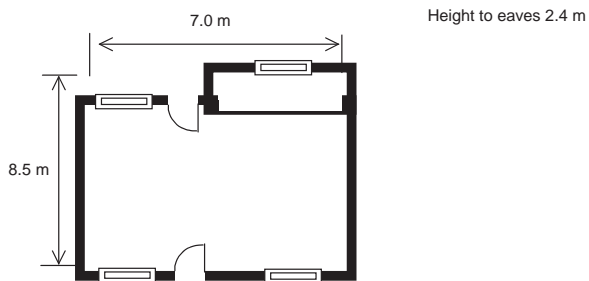

Table F4 Data for the four bedroom detached house with condensing gas boiler

Element	Description	Area	U-value
Wall	Brick/partial cavity fill/medium density block with insulated plasterboard	116.5	0.35
Roof	Pitched roof, insulated at ceiling level, insulation between and above joists	50.0	0.16
Ground floor	Suspended timber, insulated	50.0	0.25
Windows and doors	Double glazed low-E, wood frame	25.0	2.0
Heating	Central heating with condensing gas boiler (efficiency 90%)		
<b>SAP rating = 101</b>			
<b>CI = 8.0</b>			

## Example 5 – Two bedroom bungalow

Diagram F5: Plan of two bedroom bungalow



**Table F5 Data for the two bedroom bungalow with condensing gas boiler**

Element	Description	Area	U-value
Wall	Brick/partial cavity fill/medium density block with insulated plasterboard	64.2	0.35
Roof	Pitched roof, insulated at a ceiling level, insulation between and above joists	56.7	0.16
Ground floor	Concrete suspended beam and medium density block, insulated	56.7	0.25
Windows and doors	Double glazed low-E, PVC-U frame	14.2	2.0
Heating	Central heating with condensing gas boiler (efficiency 91%)		
		<b>SAP rating = 100</b>	
		<b>CI = 8.0</b>	

## Appendix G: Carbon index

**G1** SAP is the Government's Standard Assessment Procedure for the energy rating of dwellings. The SAP 1998 publication sets out the method of calculation of the SAP energy rating. It also provides for the optional calculation of CO<sub>2</sub> emissions, expressed in tonnes/year.

**G2** This Appendix provides an amendment to SAP 1998, defining the Carbon Index (CI) which can be used for demonstrating compliance for dwellings. The CI is based on the CO<sub>2</sub> emission figure, but adjusted for floor area so that it is essentially independent of dwelling size for a given built form.

**G3** The version of the SAP 1998 worksheet incorporating the calculation of the Carbon Index is known as Version 9.61.

**G4** SAP 1998 will be superseded by SAP 2001, to be published later in 2001.

### Extension of SAP 1998 Worksheet

#### for calculation of the Carbon Index

##### Conventional heating or community heating without CHP

**G5** Undertake the worksheet calculations following the existing SAP 1998 specification up to box (104). Continue with the calculation of boxes (104) and (107) according to the revised worksheet version 9.61 to obtain the Carbon Index.

##### Community heating with CHP

**G6** Undertake the worksheet calculations following the existing SAP 1998 specification to box (113\*). Continue with the calculation of boxes (113\*) and (116\*) according to the revised worksheet version 9.61 to obtain the Carbon Index.

**G7** The final page of the worksheet is appended with these additions. A new Table 16 is used to obtain the Carbon Index from the Carbon Factor.

#### Quotation of results

**G8** The Carbon Index should be expressed as a number between 0.0 and 10.0 rounded to one decimal place. It is anticipated that the Carbon Index will take the place of CO<sub>2</sub> emission figure. If, however, the CO<sub>2</sub> emission figure is quoted it should be expressed in tonnes/year rounded to one decimal place.

Table 16 Carbon Index

Carbon Factor (CF) kg/m <sup>2</sup>	Carbon Index (CI)	Carbon Factor (CF) kg/m <sup>2</sup>	Carbon Index (CI)
7.17 or less	10.0	30	4.4
8	9.6	32	4.2
9	9.1	34	3.9
10	8.7	36	3.7
11	8.3	38	3.5
12	8.0	40	3.3
13	7.7	45	2.8
14	7.4	50	2.4
15	7.1	55	2.0
16	6.9	60	1.7
17	6.6	65	1.4
18	6.4	70	1.1
19	6.2	75	0.8
20	6.0	80	0.6
22	5.6	85	0.3
24	5.3	90	0.1
26	5.0	92.5 or more	0
28	4.7		

Alternatively, the carbon index may be calculated by the formulae:

$$CF = CO_2 / (TFA + 45.0)$$

$$CI = 17.7 - 9.0 \log_{10} (CF)$$

where CO<sub>2</sub> is the CO<sub>2</sub> emissions in kg/year, and TFA is total floor area in m<sup>2</sup>.

**SAP WORKSHEET (version 9.61)**

*Note: boxes up to box (100) are identical to SAP version 9.60*

**Carbon dioxide emissions from fuel use for conventional heating and community heating without CHP**

	Energy, GJ/year		Emission factor (Table 15)	=	Emissions (kg/year)
Water heating - from box (51) <i>if heated by community boilers (51) × (85*) ÷ 0.75</i>	<input type="text"/>	×	<input type="text"/>	=	<input type="text"/> (101)
Space heating, main - from box (85) <i>if heated by community boilers (87*) ÷ 0.75</i>	<input type="text"/>	×	<input type="text"/>	=	<input type="text"/> (102)
Space heating, secondary - from box (86) <i>if heated by community boilers enter '0'</i>	<input type="text"/>	×	<input type="text"/>	=	<input type="text"/> (103)
Electricity for pumps and fans - box (87) or (88*)	<input type="text"/>	×	<input type="text"/>	=	<input type="text"/> (104)
Total CO <sub>2</sub> (space and water), kg/year [(101) + (102) + (103) + (104)] =				=	<input type="text"/> (105)
Total CO <sub>2</sub> (space and water), tonnes/year			(105) ÷ 1000 =		<input type="text"/> (105a)
Carbon Factor (CF) = (105) ÷ [(5) + 45.0]				=	<input type="text"/> (106)
Carbon Index (Table 16)				=	<input type="text"/> (107)

**Carbon dioxide emissions from fuel use for community heating schemes with CHP**

Electrical efficiency of CHP unit (e.g. 0.25) <i>from operational records or the CHP design specification</i>			<input type="text"/>	(101*)
Heat efficiency of CHP unit (e.g. 0.50) <i>from operational records or the CHP design specification</i>			<input type="text"/>	(102*)
CO <sub>2</sub> emission factor for the CHP fuel from Table 15			<input type="text"/>	(103*)
CO <sub>2</sub> emission factor for electricity from Table 15			<input type="text"/>	(104*)
Calculate CO <sub>2</sub> emitted by CHP per GJ of generated electricity	(103*) ÷ (101*)	=	<input type="text"/>	(105*)
Heat to Power ratio (GJ heat/GJ electricity) <i>enter if known, otherwise (102*) ÷ (101*)</i>			<input type="text"/>	(106*)
Calculate CO <sub>2</sub> emission factor for heat <i>if negative enter "0" in box (107*)</i>	[(105*) - (104*)] ÷ (106*)	=	<input type="text"/>	(107*)
Water heated by CHP, (51) × (83*) × (85*) =	GJ/year	box (107*)	<input type="text"/>	(108*)
		Table 15	<input type="text"/>	
Water heated by boilers, (51) × (84*) × (85*) ÷ 0.75	box (51*)	Table 15	<input type="text"/>	(109*)
If water heated by immersion heater, box (51)	box (86*)	box (107*)	<input type="text"/>	(110*)
Space heating from CHP, box (86*)	Table 15		<input type="text"/>	(111*)
Space heating from boilers, (87*) ÷ 0.75	Table 15		<input type="text"/>	(112*)
Electricity for pumps and fans, box (88*)			<input type="text"/>	(113*)
Total CO <sub>2</sub> (space and water), kg/year	[(108*) + ... + (113*)]	=	<input type="text"/>	(114*)
Total CO <sub>2</sub> (space and water), tonnes/year	(105) ÷ 1000	=	<input type="text"/>	(114a*)
Carbon Factor (CF)	(114*) ÷ [(5) + 45.0]	=	<input type="text"/>	(115*)
Carbon Index (Table 16)			<input type="text"/>	(116*)

<sup>2</sup> **BS EN 12664:2001** Thermal performance of building materials and products – Determination of thermal resistance by means of guarded hot plate and heat flow meter methods – Dry and moist products of low and medium thermal resistance

<sup>3</sup> **BS EN 12667:2000** Thermal performance of building materials and products – Determination of thermal resistance by means of guarded hot plate and heat flow meter methods – Products of high and medium thermal resistance

<sup>4</sup> **BS EN 12939:2001** Thermal performance of building materials and products – Determination of thermal resistance by means of guarded hot plate and heat flow meter methods – Thick products of high and medium thermal resistance

<sup>5</sup> **BS EN ISO 8990:1996** Thermal insulation – Determination of steady-state thermal transmission properties - Calibrated and guarded hot box

<sup>6</sup> **BS EN ISO 12567-1:2000** Thermal performance of windows and doors – Determination of thermal transmittance by hot box method – Part 1: Complete windows and doors

<sup>8</sup> **BS EN ISO 6946:1997** Building components and building elements – Thermal resistance and thermal transmittance – Calculation method

<sup>9</sup> **BS EN ISO 13370:1998** Thermal performance of buildings – Heat transfer via the ground – Calculation methods

<sup>10</sup> **BS EN ISO 10077-1:2000** Thermal performance of windows, doors and shutters – Calculation of thermal transmittance – Part 1: Simplified methods

<sup>11</sup> **prEN ISO 10077-2** Thermal performance of windows, doors and shutters – Calculation of thermal transmittance - Part 2: Numerical method for frames

<sup>14</sup> **BS EN ISO 10211-1:1996** Thermal bridges in building construction – Calculation of heat flows and surface temperatures – Part 1: General methods

<sup>15</sup> **BS EN ISO 10211-2:2001** Thermal bridges in building construction – Calculation of heat flows and surface temperatures – Part 2: Linear thermal bridges

<sup>16</sup> **BS EN 12524:2000** Building materials and products – Hygrothermal properties – Tabulated design values

<sup>23</sup> **BS 8206:1992: Part 2: Lighting for buildings: Code of practice for daylighting**

**BS 699:1984** Specification for copper direct cylinders for domestic purposes

**BS 1566-1:1984** Copper indirect cylinders for domestic purposes. Specification for double feed indirect cylinders

**BS 3198:1981** Specification for copper hot water storage combination units for domestic purposes

**BS 7206:1990** Specification for unvented hot water storage units and packages

<sup>28</sup> **BS 5864:1989** Specification for installation in domestic premises of gas-fired ducted air heaters of rated output not exceeding 60 kW

**BS 5422:2001** Method for specifying thermal insulating materials for pipes, tanks, vessels, ductwork and equipment operating within the temperature range  $-40^{\circ}\text{C}$  to  $+700^{\circ}\text{C}$

<sup>36</sup> **BS 7913:1998** The principles of the conservation of historic buildings



**The Stationery Office**

<sup>1, 24</sup> Limiting thermal bridging and air leakage: Robust construction details for dwellings and similar buildings, 2001

**Building Research Establishment (BRE)  
(published by CRC Ltd)**

<sup>7</sup> Conventions for the calculation of U-values: expected publication date early 2002

<sup>13</sup> U-value calculation procedure for light steel frame walls: expected publication date early 2002

<sup>25</sup> IP 17/01 Assessing the effects of thermal bridging at junctions and around openings

**Building Research Energy Conservation  
Support Unit (BRECSU)**

<sup>19</sup> SAP: The Government's Standard Assessment Procedure for Energy Rating of Dwellings

<sup>29, 34</sup> GPG 302, 2001: Controls for domestic central heating and hot water systems

<sup>31</sup> GIL 20, 1995: Low energy domestic lighting

<sup>33</sup> GIL 59, 2000: Central heating specifications (CHeSS)

<sup>35</sup> GPG 155: Energy efficient refurbishment of existing housing

**British Cement Association (BCA) and  
National House Building Council (NHBC)**

<sup>12, 21</sup> Approved Document – Basements for dwellings, 1997, ISBN 0-7210-1508-5

**Chartered Institution of Building Services  
Engineers (CIBSE)**

<sup>17</sup> Guide A: Environmental design, Section A3: Thermal properties of building structures, 1999

<sup>26</sup> TM 23:2000 Testing of building for air leakage

**Department of the Environment (DoE) and  
Department for National Heritage (DNH)**

<sup>20</sup> Planning and the historic environment, Planning Policy Guidance PPG 15, DoE/DNH, September 1994. (In Wales refer to Planning Guidance Wales Planning Policy First Revision 1999 and Welsh Office Circular 61/96 Planning and Historic Environment: Historic Buildings and Conservation Areas.)

**Waterheater Manufacturers Association  
(WMA)**

<sup>27</sup> Performance specification for thermal stores, 1999

**Society for the Protection of Ancient  
Buildings (SPAB)**

<sup>37</sup> Information Sheet 4: The need for old buildings to breathe, 1986.



---

# Approved Documents

---

The following documents have been approved and issued by the Secretary of State for the purpose of providing practical guidance with respect to the requirements of the Building Regulations 2000.

**Approved Document A – Structure:** 1992 Edition, fourth impression (with amendments) 1994, further amended 2000.

**Approved Document B – Fire safety:** 2000 Edition, amended 2000.

**Approved Document C – Site preparation and resistance to moisture:** 1992 Edition, second impression (with amendments) 1992, further amended 2000.

**Approved Document D – Toxic substances:** amended 1992, further amended 2000.

**Approved Document E – Resistance to the passage of sound:** 1992 Edition, second impression (with amendments) 1992, further amended 2000.

**Approved Document F – Ventilation:** 1995 Edition, amended 2000.

**Approved Document G – Hygiene:** 1992 Edition, second impression (with amendments) 1992, further amended 2000.

**Approved Document H – Drainage and waste disposal:** 2002 Edition.

**Approved Document J – Combustion appliances and fuel storage systems:** 2002 Edition.

**Approved Document K – Protection from falling, collision and impact:** 1998 Edition, amended 2000.

**Approved Document L1 – Conservation of fuel and power in dwellings:** 2002 Edition.

**Approved Document L2 – Conservation of fuel and power in buildings other than dwellings:** 2002 Edition.

**Approved Document M – Access and facilities for disabled people:** 1999 Edition, amended 2000.

**Approved Document N – Glazing – safety in relation to impact, opening and cleaning:** 1998 Edition, amended 2000

**Approved Document to support regulation 7 – Materials and workmanship:** 1999 Edition, amended 2000.